

# **CHAPTER ONE**

## **INTRODUCTION TO SOIL MECHANICS**

### **Lecture Notes**

## **1.Introduction**

**Geotechnical Engineering** is a division of civil engineering concerned with the engineering behavior of earth materials. Geotechnical engineering is a science that explains mechanics of soil and rock. It focused on the analysis, design, and construction of foundations, slopes, retaining structures, embankments, roadways, tunnels, levees, wharves, landfills and other systems that are made of or are supported by soil or rock.

**Geotechnical Engineering contains :**

1. Soil mechanics 2. Foundation engineering

**Soil Mechanics:** that describes the behavior of soils and determine the relevant physical/mechanical and chemical properties of these soils; soil mechanics provides the theoretical basis for analysis in geotechnical engineering.

**Foundation Engineering:** is the aspect of engineering concerned with the evaluation of the ability of the earth to support load, and the design of a substructure to transmit the load of the superstructure to the earth

**Soil:** is natural mineral particles that can be separated into relatively small pieces and may contain water, air, or organic materials (derived from the decay of vegetation).

**Rock:** is a natural material comprised of mineral particles so firmly bonded together that relatively high effort is required to separate the particles (i.e., blasting or heavy crushing forces).

## 2. Historical Development of Geotechnical Engineering

Before 18th century: the art of geotechnical engineering was based on only past experiences through a succession of experimentation without any real scientific character. Civilizations such as the Nile (Egypt), the Tigris and Euphrates (Mesopotamia), the Huang Ho (Yellow River, China), and the Indus (India)

One of the most famous examples of problems related to soil-bearing capacity in the construction of structures before the 18th century is the Leaning Tower of Pisa in Italy. Construction of the tower began in 1173 A.D.

(1700 –1776) This period concentrated on studies relating to the natural slope and unit weights of various types of soils, as well as the semi-empirical earth pressure theories.

Henri Gautier (1660–1737), Forest de Belidor (1671–1761)

(1776 –1856) During this period, most of the developments in the area of geotechnical engineering came from engineers and scientists in France. Practically all theoretical considerations used in calculating lateral earth pressure on retaining walls were based failure surface in the soil.



Charles A. Coulomb (1736–1806)



William M. Rankine (1820–1872)

(1856 –1910) Several experimental results from laboratory tests on sand appeared in the literature in this period.

Henri Philibert Gaspard Darcy (1803–1858). Published a study on the permeability of sand filters

Joseph Valentin Boussinesq (1842–1929), was the development of the theory of stress distribution under loaded bearing areas in a homogeneous.

Osborne Reynolds (1842–1912) demonstrated the phenomenon of dilation in the sand.



(1910 –1927) In this period, results of research conducted on clays were published in which the fundamental properties and parameters of clay were established.

Albert Mauritz Atterberg (1846–1916), a Swedish chemist and soil scientist, defined clay-size fractions as the percentage by weight of particles smaller than 2 microns in size

Karl Terzaghi (1883–1963) developed the theory of consolidation for clay as we know today. In 1925, Terzaghi became recognized as the leader of the new branch of civil engineering called soil mechanics.

1927 – Now

Casagrande – Peck - Bjurrum – Skempton – Tomlinson



### 3. The Origin of Soils

In general, soils are formed by **weathering** of rocks. Rocks can be divided into three basic types: **igneous**, **sedimentary**, and **metamorphic**.

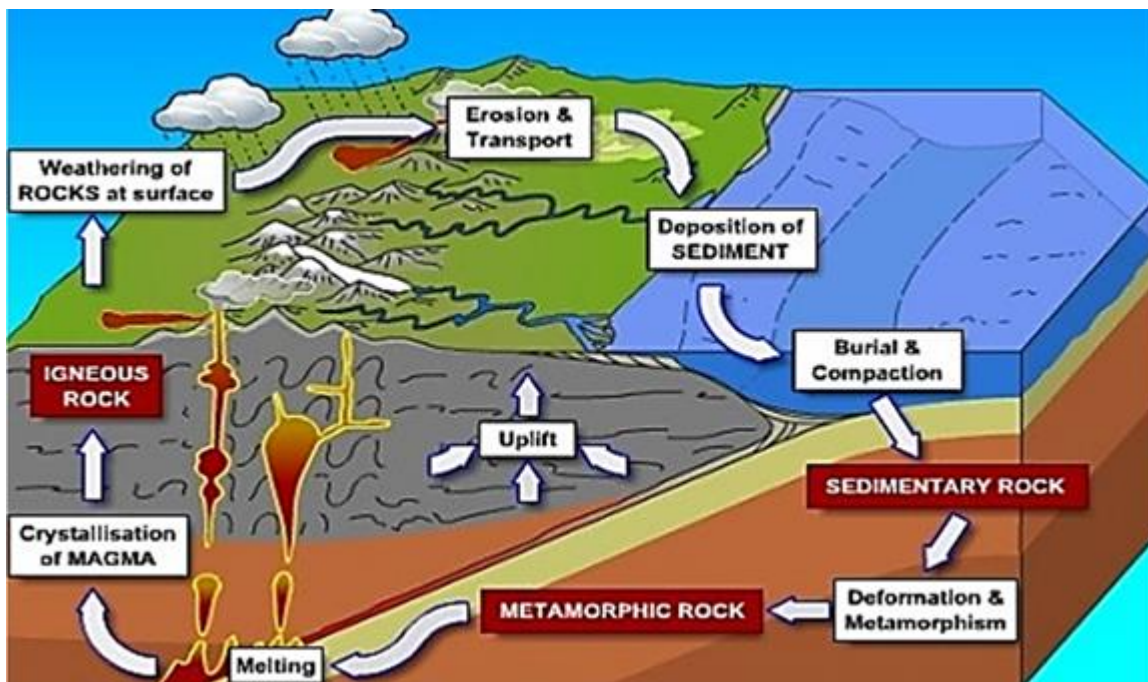

**Weathering** is the process of breaking down rocks by **mechanical** and **chemical** processes into smaller pieces. The products of weathering may stay in the same place or may be moved to other places by ice, water, wind, and gravity.

**Mechanical weathering** may be caused by the expansion and contraction of rocks from the continuous gain and loss of heat. The processes that cause physical weathering are:-

- Freezing and thawing
- Temperature changes
- Erosion (Abrasion)

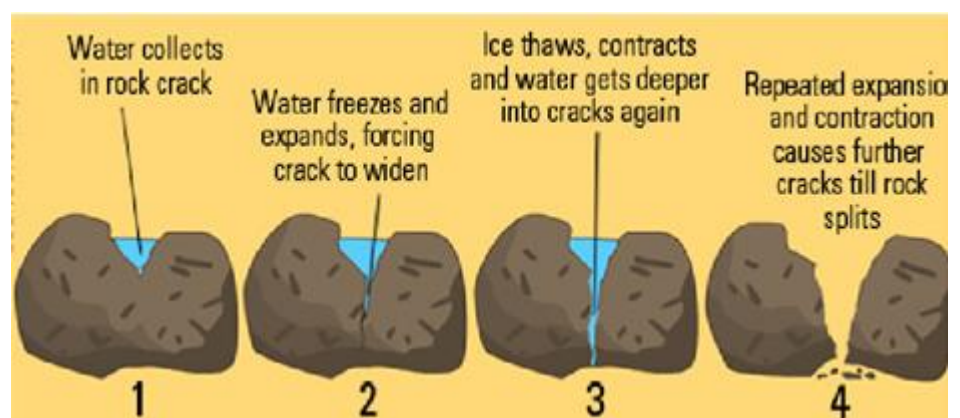

Activity of plants and animals including man

For example, water seeps into the pores and existing cracks in rocks. As the temperature drops, the water freezes and expands. The pressure exerted by ice because of volume expansion is strong enough to break down even large rocks.

Other physical agents: glacier ice, the wind, running water of streams and rivers, and ocean waves. **Its properties are the same as parent rock** Chemical weathering, the original rock minerals are transformed into new minerals by chemical reaction.

Oxidation – union of oxygen with minerals in rocks forming another mineral.

Hydration – water will enter the crystalline structure of minerals forming another group of minerals.

Hydrolysis – the release Hydrogen from water will union with minerals forming another mineral.

Carbonation – when  $\text{CO}_2$  is available with the existence of water the minerals changed to Carbonates.

The chemical weathering of plagioclase feldspars produces clay minerals, silica, and different soluble salts.

**The physical property of this product does not reflect the same properties of the parent rocks**



Depending on the method of deposition, soils can be grouped into two categories:

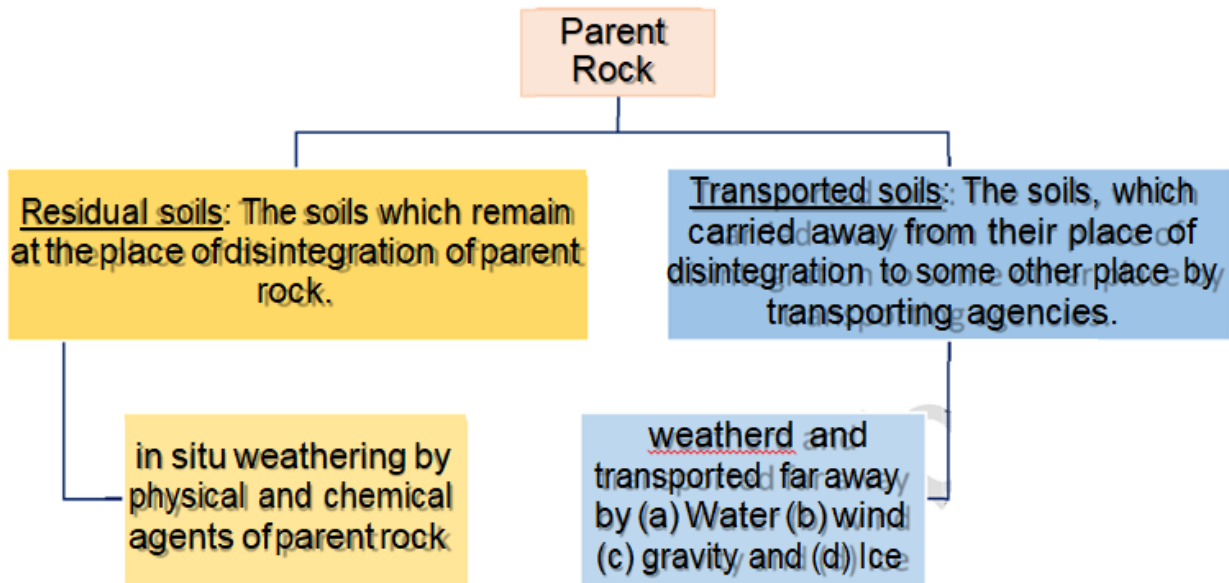

- Residual soils: the soils formed by the weathered products at their place of origin

Sands: Residual sands and fragments of gravel size formed by solution and leaching of cementing material, leaving the more resistant particles; commonly quartz.

Clays: Residual clays formed by decomposition of silicate rocks, the disintegration of shales, and solution of carbonates in limestone.

- Transported soils may be classified into several groups, depending on their mode of transportation and deposition:
  - Glacial soils—formed by transportation and deposition of glaciers



- Alluvial soils—transported by running water and deposited along streams.



- Lacustrine soils—formed by deposition in quiet lakes.



- Marine soils—formed by deposition in the seas.



- Aeolian soils—transported and deposited by the wind.



- Colluvial soils—formed by movement of soil from its original place by gravity, such as during landslides

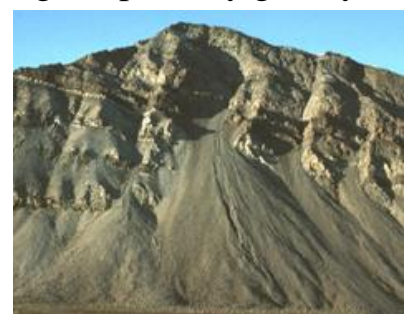



- Organic Soils: Accumulation of highly organic material formed in place by the growth and subsequent decay of plant life.



- Peat: A somewhat fibrous aggregate of decayed and decaying vegetation matter having a dark color



- Muck: Peat deposits which have advanced in the stage of decomposition to such extent that the botanical character is no longer evident. Very compressible, entirely unsuitable for supporting building foundations.



## 4. Problems in Civil Engineering

The soil in civil engineering is used as a foundation material or construction material

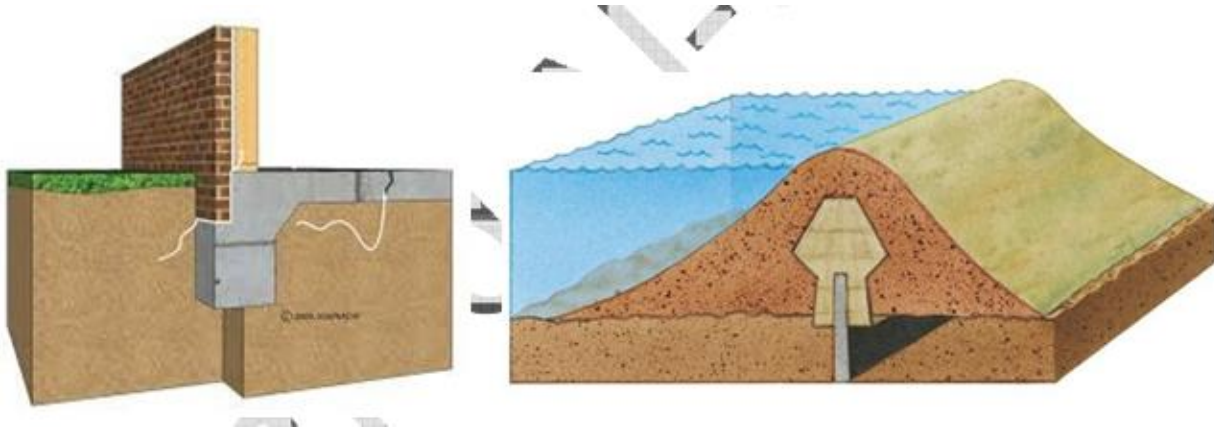

The main purpose of the studying geotechnical engineering is to find the shear strength and settlement of the soil.

### Problematic soils

#### • Expansive Soils

Expansive soils are distinguished by their potential for great volume increase upon access to moisture. Soils exhibiting such behavior are mostly clays.

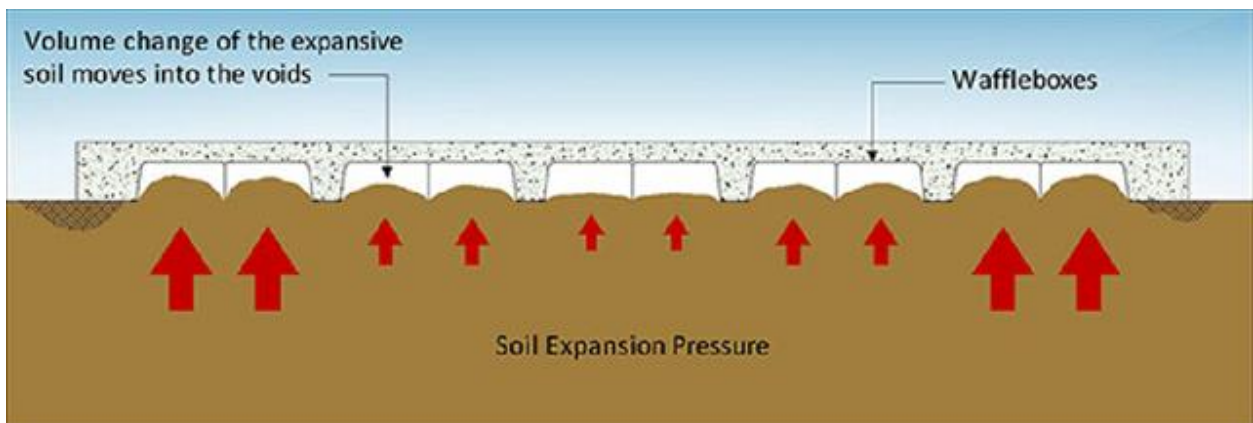

## ● Collapsing Soils

Collapsing soils are distinguished by their potential to undergo a large decrease in volume upon an increase in moisture content even without an increase in external loads.



## ● Other Problematic soils

Karst Topography: is a landscape formed from the dissolution of soluble rocks such as limestone, dolomite, and gypsum. It is characterized by underground drainage systems with sinkholes and caves

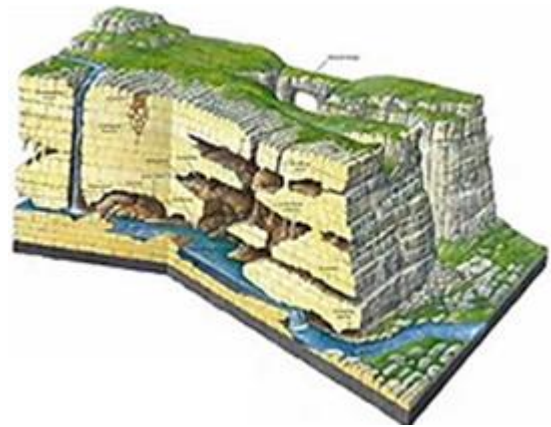

Calcareous Soils: soils have often more than 15%  $\text{CaCO}_3$  in the soil that may occur in various forms (powdery, nodules, crusts etc.) They are relatively widespread in the drier areas of the earth.



Quick Clays: is so unstable that when is subjected to sufficient stress, the material behavior may



transition from that of a particulate material to that of a fluid.

Dispersive Clays: are those in which the clay content has a high percentage of sodium. This clay fraction readily breaks down to form a suspension in water.



## **5. A Preview of Soil Behavior**

The soil is the particulate system. These particles make soil are not strongly bonded together like metal, and the soil particles are free to move on one another, but cannot move relative to each other as easily as an element in the fluid. Soil mechanics distinguished from solid mechanics and fluid mechanics that treats the stress-strain behavior



The sequences of the particulate system are:

**1.5.1 Nature of soil deformation** due

to contact Bending of plate-like particles

Inter particle sliding (75-80)%

Thus, the stress – strain behavior of soil is strongly nonlinear and irreversible

of deformation

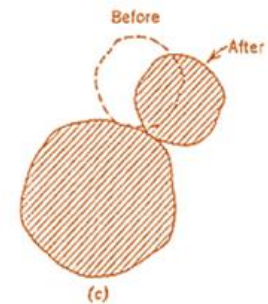
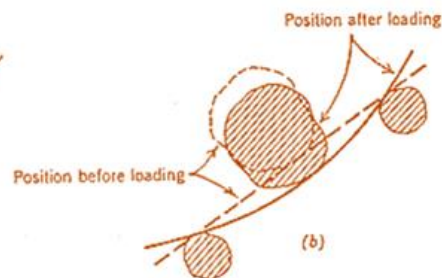
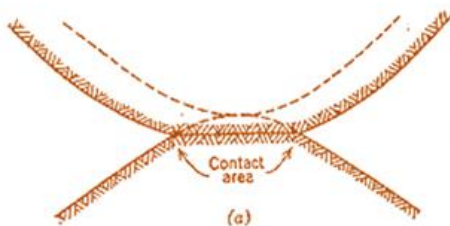
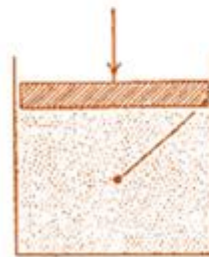
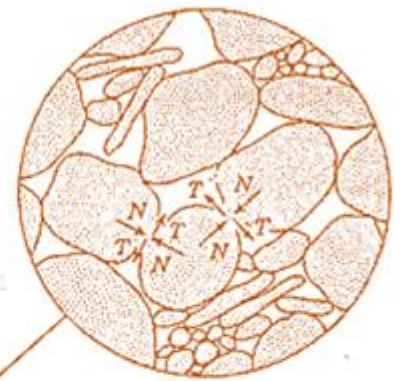

### 1.5.2 Role of pore phase

The soil is multiphase, consists of a mineral called mineral skeleton, and pores.

If all pores **filled with air**, then the soil is **dry**, if all pores **filled with water** the soil is **saturated**, and if some of the pores **filled with air and some filled with water** the soil are **partially saturated**.

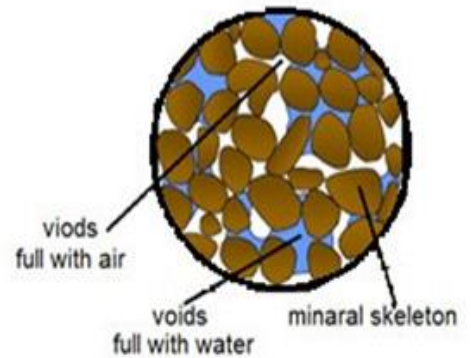

❖ The soil is saturated and the level of water in the supply tank same as the same level in soil box. Thus, the pressure in the water is **hydrostatic**.

❖ If the water in the supply tank rises, then there is an upward flow through soil

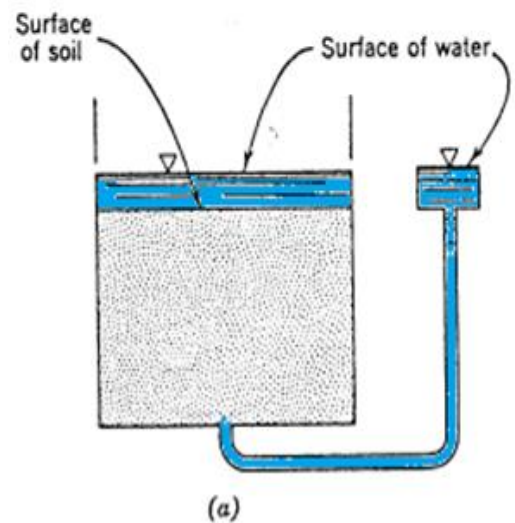

❖ Now if the supply tank further rises, the water pressure increased until reached a case where the sand is boiling by the upward movement of water, this called "quick condition." At this stage, the volume of soil increased and the soil has very low strength.

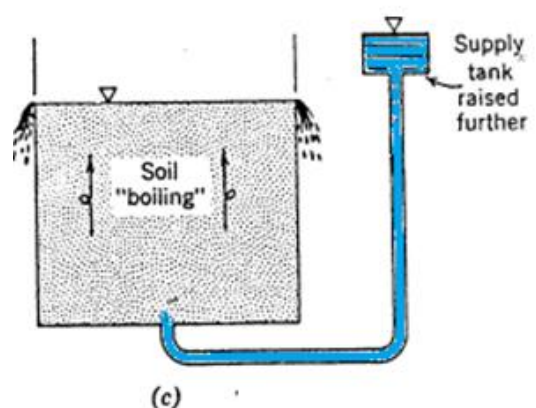
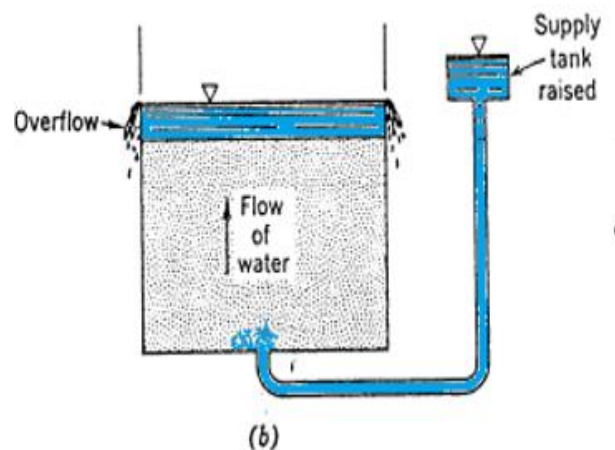

### 1.5.3 Sharing the load

Since the soil is a multiphase system, it's expected that the load applied to soil would be carried by the mineral skeleton and by pore fluid.

The saturated soil (a) can be modeled as spring and water (b).

If the load is applied to the piston and the valve is kept closed (c), in this case, there is no change in soil volume because the water is incompressible and hence all load applied will carry by water. Now the valve will open (d), the fluid pressure will force water through this valve and the water escape,

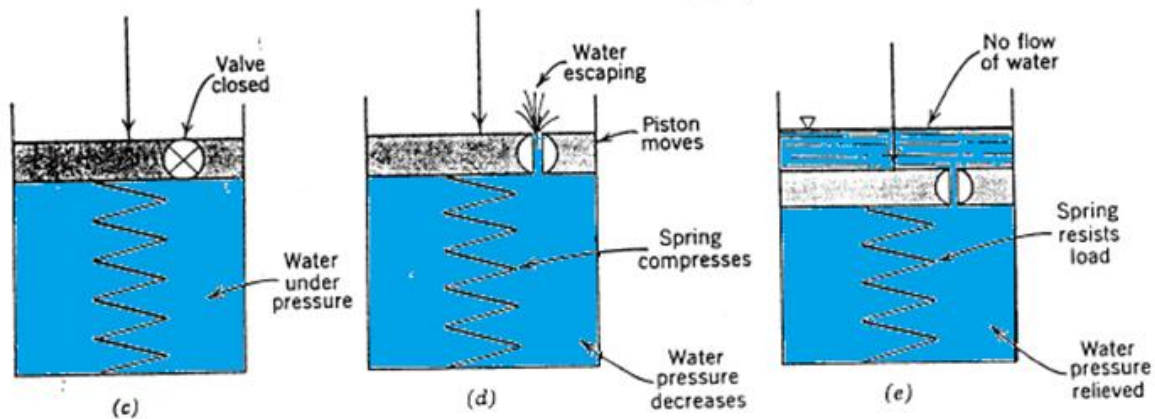
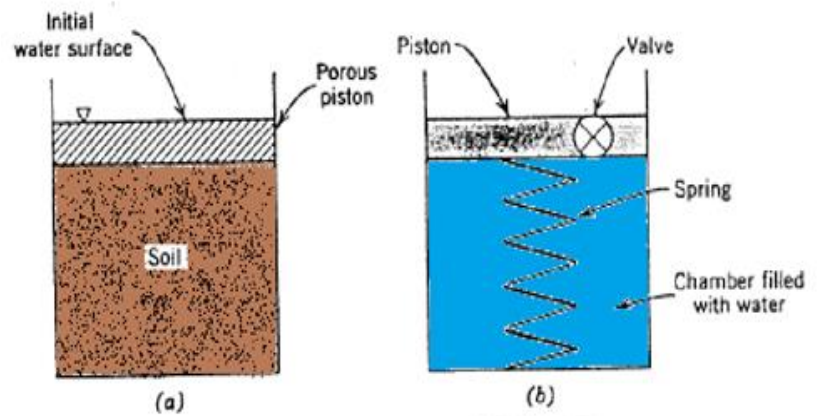

the spring shortens and begins to carry a fraction of the applied load. Eventually, a condition is reached in which all applied load is carried by the spring, and the pressure of water returned to the original hydrostatic condition, and there is no further flow of water (e). The soil properties will change, and the amount of volume change in soil is equal to the water squeezed from the sample. The figure shows the load sharing with time; the

time depends on soil permeability.

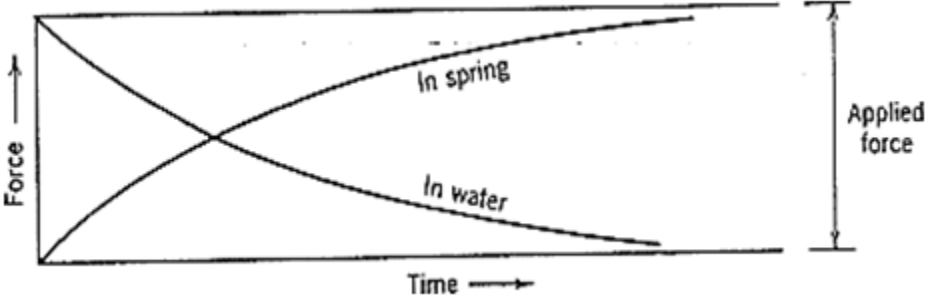



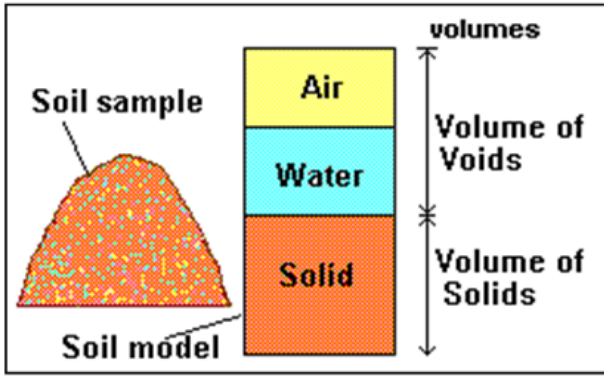

## CHAPTER TWO

### *BASIC*

### *CHARACTERISTICS*

### *OF SOILS*

### Lecture Notes



## Soil Mechanics 3<sup>rd</sup> Stage

Up copyrights 2017

## 2.1 The Physical State of a Soil Sample

Soils can be of either two-phase or three-phase composition.

Soils can be of either two-phase or three-phase composition.

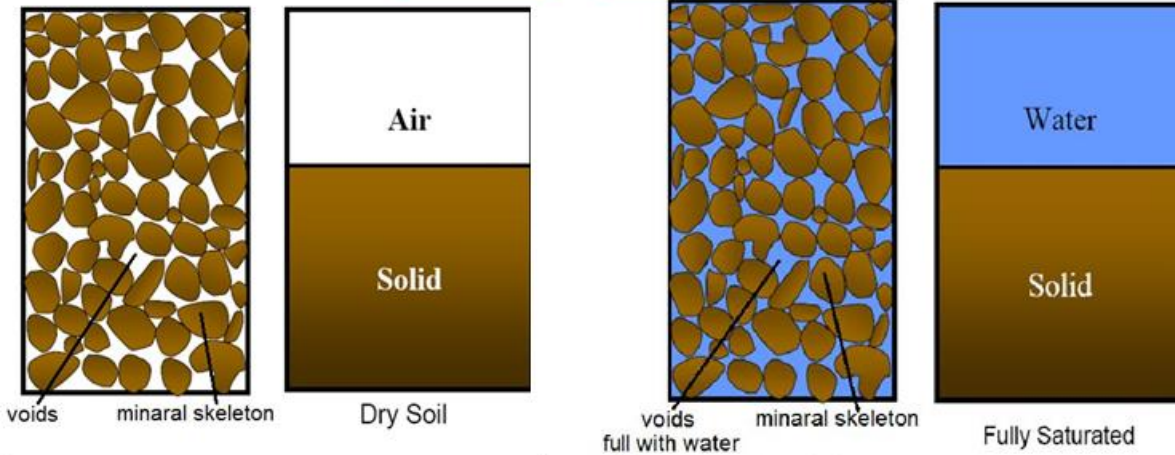

A Completely dry soil is two phases, the solid soil particles and pore air

A fully saturated soil is also two-phases, composed of solid soil particles and pore water

A partially saturated soil is three-phase, composed of solid soil particles, pore water and pore air.

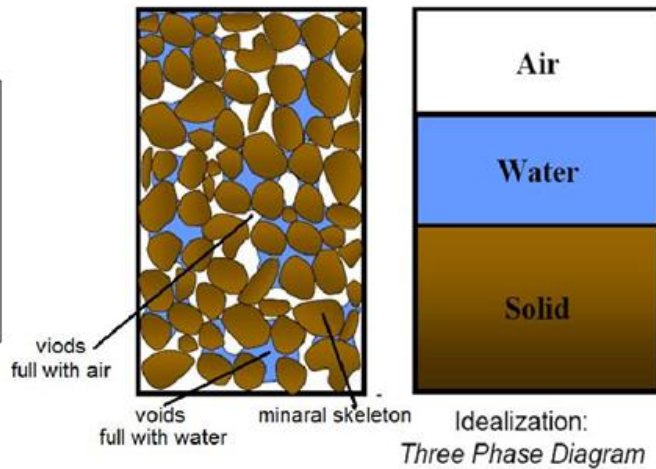

The physical and engineering properties of soil depend on the percentage of each element (solid – water – air)

$V_a$  = volume of air  
 $V_w$  = volume of water  
 $V_s$  = volume of solids  
 $V_v$  = volume of voids =  $V_a + V_w$   
 $V$  = total volume =  $V_a + V_w + V_s$   
 $\quad\quad\quad = V_v + V_s$   
 $W_a$  = weight of air = 0  
 $W_w$  = weight of water  
 $W_s$  = weight of solids  
 $W$  = total weight =  $W_w + W_s$

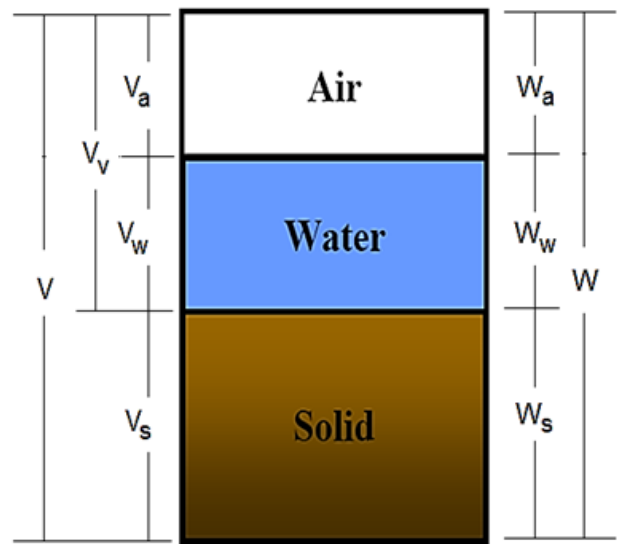

### 2.1.1 Volume Relationships

1. Void ratio: It is the ratio of the volume of voids to the volume of solids. Void ratio = (volume of voids / volume of solids)

$$\therefore e = V_v / V_s.$$

2. Porosity: It is the ratio of the volume of voids to the total volume. Porosity = (volume of voids / total volume)

$$\therefore n = (V_v / V) \%$$

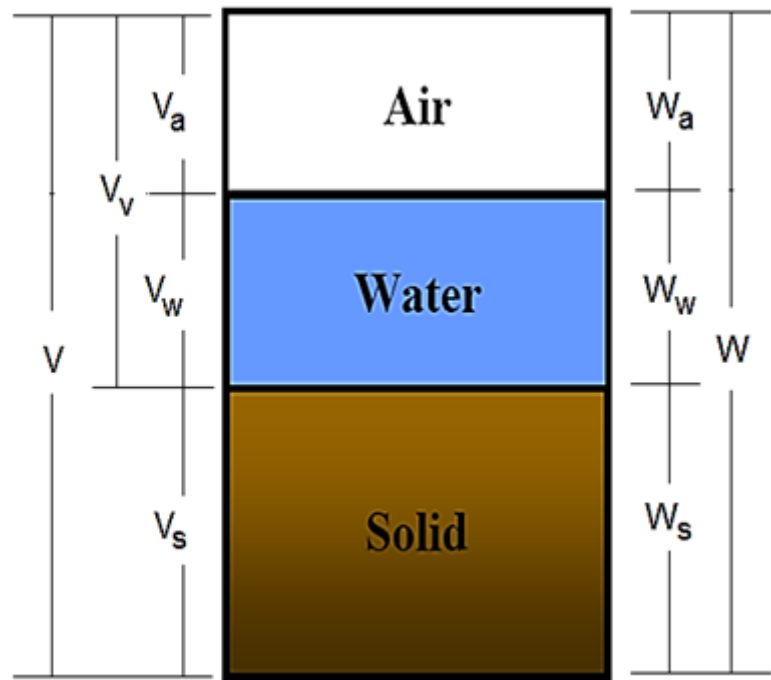

3. Air content: It is the ratio of the volume of air to the volume of voids. Air content = (volume of air / volume of voids)

$$\therefore ac = (V_a / V_v)$$

4. Percentage Air Voids: It is the ratio of the volume of air to total volume.

Percentage air voids = (volume of air/ total volume)

$$\therefore n_a = (V_a/V)\%$$

If the volume of the void is taken as "e," the volume of solids by definition of porosity will be "1" and total volume is "1+e".

$$\therefore n = \frac{V_v}{V} = \frac{e}{1+e}$$

If the volume of voids is taken as "n," the volume of solids, by definition of void ratio will be "1-n" and total volume equal to "1".

$$\therefore e = \frac{V_v}{V_s} = \frac{n}{1-n}$$

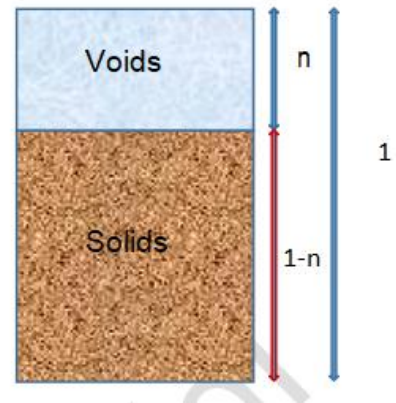

5. Degree of Saturation: It is the ratio of the volume of water to the volume of voids.

Degree of saturation = (volume of water/ volume of voids)

$$s = (V_w/V_v) \%$$

When  $s = 0\%$

dry soil

$s = 100\%$

saturated soil

$0 < s < 100\%$

partially saturated soil

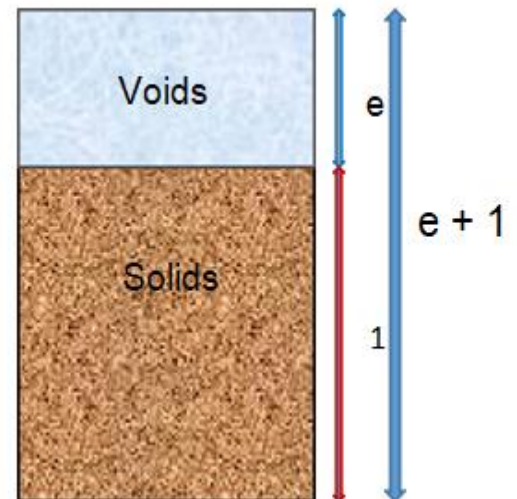

### 2.1.2 Weight Relationships

6. Water Content or Moisture Content: it is the ratio of the weight of water to the weight of soils.

Water content = (weight of water / weight of dry soil)\*100%

$$w = \frac{W_w}{W_s} * 100\%$$

### 2.1.3 Soil Unit Weight

7. Total unit weight (Bulk unit weight) ( $\gamma_t$ ): It is the total weight of soil per total volume

Total unit weight = (total weight of soil mass / total volume of soil mass)

$$\gamma_t = \frac{W}{V} \dots \text{N/m}^3 \text{ or } \text{kN/m}^3$$

8. Dry Unit Weight ( $\gamma_d$ ): It is the weight of soil solids per total volume of the soil mass.

Dry unit weight = (total weight of soil solids / total volume of soil mass)

$$\gamma_d = \frac{W_s}{V} \dots \text{kN/m}^3$$

9. Water Unit Weight ( $\gamma_w$ ): It is the weight of water per total volume of the water mass.

Water unit weight = 9.81 kN/m<sup>3</sup>

10. Saturated Unit Weight ( $\gamma_{sat}$ ): It is the weight of saturated soil per unit of total volume of the soil mass.

Saturated unit weight = (total weight of saturated soil mass / total volume of soil mass)

$$\gamma_{sat} = \frac{W_{sat}}{V} \dots \text{kN/m}^3$$

11. Submerged Unit Weight (Buoyant Unit Weight) ( $\gamma_b$ ) = ( $\gamma_{sat}$ ) - ( $\gamma_w$ )

### 2.1.4 Soil Density

Total density (Bulk density),  $\rho = M/V$

Dry density,  $\rho_d = M_d/V \dots \text{kg/m}^3$

Saturated density,  $\rho_{sat} = M_{sat} / V \dots \text{kg/m}^3$

Submerge density,  $\rho_b = \rho_{sat} - \rho_w \text{ kg/m}^3$ ,  $\rho_w = 1000 \text{ kg/m}^3$   $1000 \text{ kg} = 9.81 \text{ kN}$

12. Unit Weight of Solids ( $\gamma_s$ ): It is the ratio of weight of solids to the volume of

solids.

$$\gamma_s = W_s / V_s$$

13. Specific Gravity ( $G_s$ ): It is the ratio of the weight of a given volume of soil solids to the weight of an equal volume of distilled water.

Specific gravity = (weight of a given volume of soil solid / weight of an equal volume of distilled water)

$$G_s = W_s / W_w = \gamma_s / \gamma_w \quad (\text{no unit})$$

SPECIFIC GRAVITY	
gravel	2.65 - 2.68
sand	2.65 - 2.68
<u>silty</u> sand	2.66 - 2.70
silts	2.66 - 2.70
inorganic clays	2.70 - 2.80
organic soils	variable may fall below 2.0
soils high in mica, iron	2.75 - 2.85

Important Relationship :

$$S e = \omega G_s$$

$$\gamma_t = \frac{G + s.e}{1 + e} \gamma_w = \frac{1 + \omega}{1 + e} G \gamma_w$$

$$d = \frac{G}{1 + e} \gamma_w = \frac{\gamma_t}{1 + \omega}$$

$$b = \frac{(G - 1)}{1 + e} \gamma_w$$

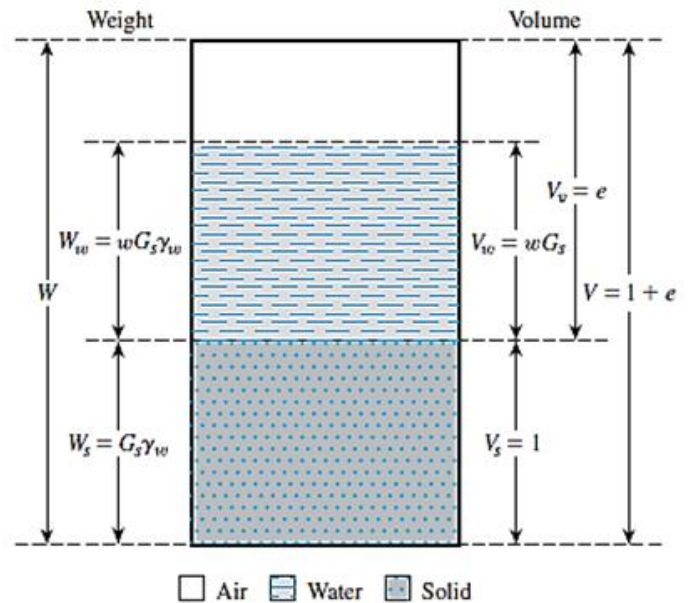

- Prove :  $S.e = G_s \cdot W.c$

$$S = \frac{V_w}{V_v}$$

$$V_w = \frac{W_w}{\gamma_w} = \frac{w G_s \gamma_w}{\gamma_w} = w G_s$$

$$S = \frac{w G_s}{e}$$

$S.e = \omega \cdot G_s$ , if soil is saturated then  $e = \omega \cdot G_s$

$$\gamma = \frac{W}{V} = \frac{W_s + W_w}{V} = \frac{G_s \gamma_w + w G_s \gamma_w}{1 + e} = \frac{(1 + w) G_s \gamma_w}{1 + e}$$





Various Forms of Relationships for  $\gamma$ ,  $\gamma_d$ , and  $\gamma_{sat}$

Moist unit weight ( $\gamma$ )		Dry unit weight ( $\gamma_d$ )		Saturated unit weight ( $\gamma_{sat}$ )	
Given	Relationship	Given	Relationship	Given	Relationship
$w, G_s, e$	$\frac{(1+w)G_s\gamma_w}{1+e}$	$\gamma, w$	$\frac{\gamma}{1+w}$	$G_s, e$	$\frac{(G_s+e)\gamma_w}{1+e}$
$S, G_s, e$	$\frac{(G_s+Se)\gamma_w}{1+e}$	$G_s, e$	$\frac{G_s\gamma_w}{1+e}$	$G_s, n$	$[(1-n)G_s+n]\gamma_w$
$w, G_s, S$	$\frac{(1+w)G_s\gamma_w}{1+\frac{wG_s}{S}}$	$G_s, n$	$G_s\gamma_w(1-n)$	$G_s, w_{sat}$	$\left(\frac{1+w_{sat}}{1+w_{sat}G_s}\right)G_s\gamma_w$
$w, G_s, n$	$G_s\gamma_w(1-n)(1+w)$	$G_s, w, S$	$\frac{G_s\gamma_w}{1+\left(\frac{wG_s}{S}\right)}$	$e, w_{sat}$	$\left(\frac{e}{w_{sat}}\right)\left(\frac{1+w_{sat}}{1+e}\right)\gamma_w$
$S, G_s, n$	$G_s\gamma_w(1-n)+nS\gamma_w$	$e, w, S$	$\frac{eS\gamma_w}{(1+e)w}$	$n, w_{sat}$	$n\left(\frac{1+w_{sat}}{w_{sat}}\right)\gamma_w$
		$\gamma_{sat}, e$	$\gamma_{sat}-\frac{e\gamma_w}{1+e}$	$\gamma_d, e$	$\gamma_d+\left(\frac{e}{1+e}\right)\gamma_w$
		$\gamma_{sat}, n$	$\gamma_{sat}-n\gamma_w$	$\gamma_d, n$	$\gamma_d+n\gamma_w$
		$\gamma_{sat}, G_s$	$\frac{(\gamma_{sat}-\gamma_w)G_s}{(G_s-1)}$	$\gamma_d, S$	$\left(1-\frac{1}{G_s}\right)\gamma_d+\gamma_w$
				$\gamma_d, w_{sat}$	$\gamma_d(1+w_{sat})$

Void Ratio, Moisture Content, and Dry Unit Weight  
for Some Typical Soils in a Natural State

Type of soil	Void ratio, $e$	Natural moisture content in a saturated state (%)	Dry unit weight, $\gamma_d$
			kN/m <sup>3</sup>
Loose uniform sand	0.8	30	14.5
Dense uniform sand	0.45	16	18
Loose angular-grained silty sand	0.65	25	16
Dense angular-grained silty sand	0.4	15	19
Stiff clay	0.6	21	17
Soft clay	0.9–1.4	30–50	11.5–14.5
Loess	0.9	25	13.5
Soft organic clay	2.5–3.2	90–120	6–8
Glacial till	0.3	10	21

### Example (2.1)

For a saturated soil, show that  $\gamma_{sat} = \left( \frac{e}{w} \right) \left( \frac{1+w}{1+e} \right) \gamma_w$

### Solution

$$\begin{aligned} \gamma_{sat} &= \frac{W_{sat}}{V} = \frac{W_{sat}}{V} * \frac{W_s}{v_s} * \frac{v_s}{W_s} = \left( \frac{\frac{W_{sat}}{W_s}}{\frac{V}{v_s}} \right) * \frac{W_s}{v_s} \\ &= \left( \frac{\frac{W_s + W_w}{W_s}}{\frac{v_s + v_w}{v_s}} \right) * \frac{W_s}{v_s} * \frac{\gamma_w}{\frac{W_w}{v_w}} = \frac{e}{\omega} \left( \frac{1+\omega}{1+e} \right) \gamma_w \end{aligned}$$

**Example (2.2)**

For a moist soil sample, the following are given:

Total volume:  $V = 1.2 \text{ m}^3$ , Total mass:  $M = 2350 \text{ kg}$ , Moisture content:  $\omega = 8.6\%$ , and specific gravity of soil solids:  $G_s = 2.71$

Determine the following: (a). Moist density, (b). Dry density, (c). Void ratio (d). Porosity, (e). The degree of saturation, and (f). The volume of water in the soil sample.

Part (a)  $\rho = \frac{M}{V} = \frac{2350}{1.2} = 1958.3 \text{ kg/m}^3$

Part (b)  $\rho_d = \frac{M_s}{V} = \frac{M}{(1 + w)V} = \frac{2350}{\left(1 + \frac{8.6}{100}\right)(1.2)} = 1803.3 \text{ kg/m}^3$

Part (c)  $\rho_d = \frac{G_s \rho_w}{1 + e}$

$$e = \frac{G_s \rho_w}{\rho_d} - 1 = \frac{(2.71)(1000)}{1803.3} - 1 = 0.503$$

Part (d)

$$n = \frac{e}{1 + e} = \frac{0.503}{1 + 0.503} = 0.335$$

Part (e)

$$S = \frac{wG_s}{e} = \frac{\left(\frac{8.6}{100}\right)(2.71)}{0.503} = 0.463 = 46.3\%$$

Part (f)

$$\frac{M_w}{\rho_w} = \frac{M - M_s}{\rho_w} = \frac{M - \frac{M}{1 + w}}{\rho_w} = \frac{2350 - \left(\frac{2350}{1 + \frac{8.6}{100}}\right)}{1000} = 0.186 \text{ m}^3$$

Use the following figure and solve the problem using alternative solution

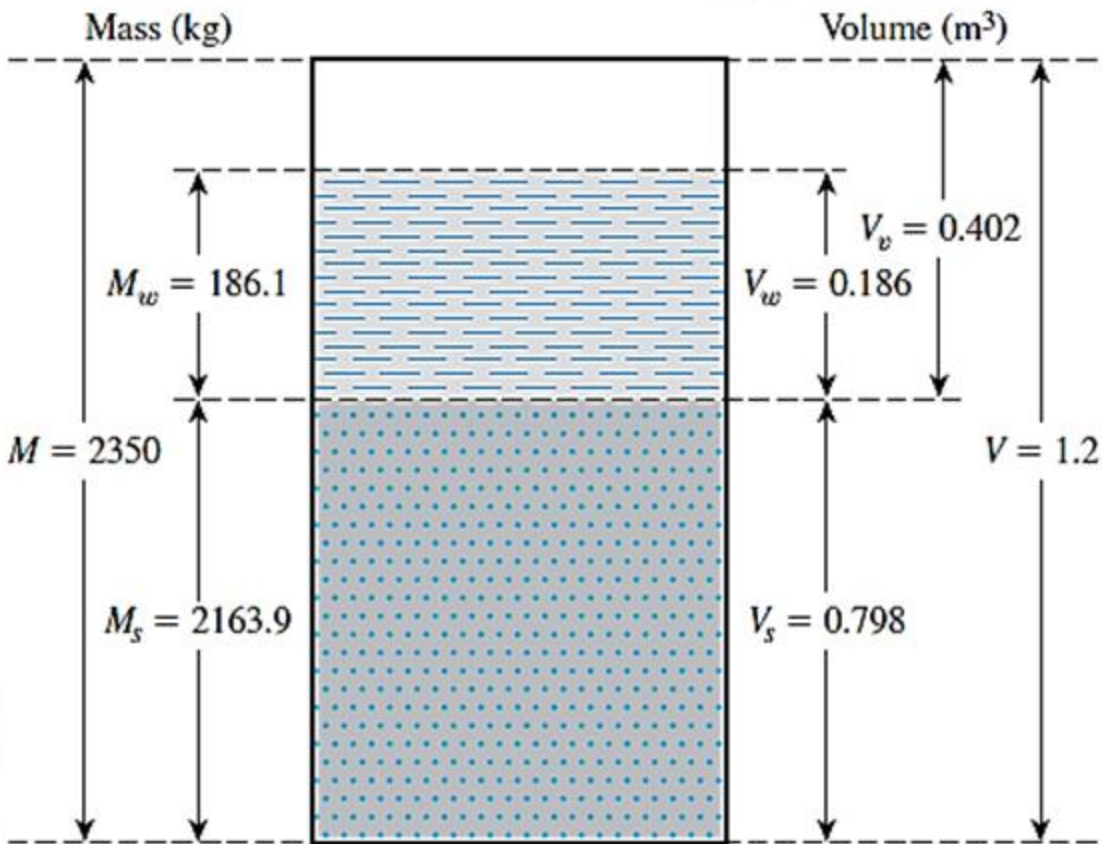

### Example (2.3)

The following data are given for a soil: Porosity;  $n = 40\%$ , Specific gravity of the soil solids;  $G_s = 2.68$ , Moisture content:  $\omega = 12\%$

Determine the mass of water to be added to 10 m<sup>3</sup> of soil for full saturation

### Solution

$$\gamma = \frac{W_s + W_w}{V} = G_s \gamma_w (1 - n)(1 + w) \implies \rho = G_s \rho_w (1 - n)(1 + w)$$

$$\gamma_{\text{sat}} = \frac{W_s + W_w}{V} = \frac{(1 - n)G_s \gamma_w + n \gamma_w}{1} = [(1 - n)G_s + n] \gamma_w$$

$$\rho_{\text{sat}} = [(1 - n)G_s + n] \rho_w$$

$$\rho = (2.68)(1000)(1 - 0.4)(1 + 0.12) = 1800.96 \text{ kg/m}^3$$

$$\rho_{\text{sat}} = [(1 - 0.4)(2.68) + 0.4] (1000) = 2008 \text{ kg/m}^3$$

$$\text{Mass water needed for } 1 \text{ m}^3 = \rho_{\text{sat}} - \rho = 2008 - 1800.96 = 207.04 \text{ kg}$$

$$\text{Total mass of water must be added} = 207.04 \times 10 = 2070.4 \text{ kg}$$

**Example (2.4)**

In its natural condition, a soil sample has a mass of 2290 g and a volume of  $1.15 \times 10^{-3} \text{ m}^3$ . After being completely dried in an oven, the mass of the sample is 2035 g. The value of  $G_s$  for the soil is 2.68. Determine the bulk density, unit weight, water content, void ratio, porosity, the degree of saturation and air content.

---

$$\text{Bulk density, } \rho = \frac{M}{V} = \frac{2.290}{1.15 \times 10^{-3}} = 1990 \text{ kg/m}^3$$

$$\begin{aligned} \text{Unit weight, } \gamma &= \frac{Mg}{V} = 1990 \times 9.8 = 19500 \text{ N/m}^3 \\ &= 19.5 \text{ kN/m}^3 \end{aligned}$$

$$\text{Water content, } w = \frac{M_w}{M_s} = \frac{2290 - 2035}{2035} = 0.125 \text{ or } 12.5\%$$

$$\begin{aligned} \text{Void ratio, } e &= G_s (1+w) \frac{\rho_w}{\rho} - 1 \\ &= \left( 2.68 \times 1.125 \times \frac{1000}{1990} \right) - 1 \\ &= 1.52 - 1 \\ &= 0.52 \end{aligned}$$

$$\text{Porosity, } n = \frac{e}{1+e} = \frac{0.52}{1.52} = 0.34 \text{ or } 34\%$$

$$\text{Degree of saturation, } S_r = \frac{wG_s}{e} = \frac{0.125 \times 2.68}{0.52} = 0.645 \text{ or } 64.5\%$$

$$\begin{aligned} \text{Air content, } A &= n(1 - S_r) = 0.34 \times 0.355 \\ &= 0.121 \text{ or } 12.1\% \end{aligned}$$

### Example (2.5)

A soil sample with  $\gamma_t/\gamma_w = 1.91$ ,  $G_s = 2.69$  and  $\omega = 29\%$ . Find  $n$ ,  $e$ , and  $S$ .

### Solution

$$G_s = \gamma_s / \gamma_w = 2.69 * 9.81 = 2.389 \text{ kN/m}^3$$

Since all values given in the example are unit less assume the  $V_s$  is  $1 \text{ m}^3$

$$\gamma_s = W_s / W_w \gg \gg W_s = 2.389 * 1 = 2.389 \text{ kN}$$

$$\gamma_t / \gamma_w = 1.91 \gg \gg \gg \gamma_t = 1.91 * 9.81 = 18.737 \text{ kN/m}^3$$

$$\omega = \frac{W_w}{W_s} \rightarrow W_w = 0.29 * 26.389 = 7.65 \text{ kN}$$

$$\text{Total weight} = W_s + W_w = 26.389 + 7.65 = 34.04 \text{ kN,}$$



$$V_t = W/V$$

$$= 34.04/18.737 = 1.817 \text{ m}^3$$

$$e = V_v/V_s = 1.817 - 1/1$$

$$= 0.817$$

$$n = e/1+e * 100\%$$

$$= 0.817/1+0.817 * 100 = 45\%$$

$$S = V_w/V_v * 100\%$$

$$V_w = 7.65/9.81 = 0.78 \text{ m}^3, S = 0.78/0.817 = 95.5\%$$

### Example (2.6)

For a saturated soil; given  $\gamma_d = 17.70 \text{ kN/m}^3$ ; and  $\omega = 18\%$ ; determine (a)  $\gamma_{\text{sat}}$ , (b) void ratio,  $e$  (c)  $G_s$ , and (d) moist unit weight when the degree of saturation is 50%.

### Solution

$S \cdot e = \omega$ .  $G_s$ , when soil saturated  $S = 100\%$

$$1 \cdot e = 0.18 * G_s, \implies G_s = \frac{e}{0.18}$$

$$\gamma_d = \frac{G_s}{1+e} \gamma_w \implies \gamma_d = \frac{\frac{e}{0.18}}{1+e} (9.81) \implies 17.70 = \frac{e}{1+e} (9.81)$$

$$\therefore e = 0.481$$

$$G_s = \frac{e}{0.18} = \frac{0.481}{0.18} = 2.672$$

$$\gamma_{sat} = \frac{e + G_s}{1 + e} (\gamma_w)$$

$$\gamma_{sat} = \frac{0.481 + 2.672}{1 + 0.481} (9.81) = 20.885 \text{ kN/m}^3$$

For  $S = 50\%$

$$S \cdot e = \omega \cdot G_s \implies 0.5 \cdot 0.481 = \omega \cdot 2.672 \implies \omega = 0.09, \omega\% = 9.0\%$$

$$\gamma_t = \frac{\omega + 1}{1 + e} G_s \gamma_t = \frac{0.09 + 2.672}{1 + 0.18} * 9.81 = 19.29 \text{ kN/m}^3$$

## 2.2 Soil Texture

Soil texture is an important soil characteristic that drives crop production and field management. The textural class of soil is determined by the sizes of particles that make up soil vary over a wide range. Soils are called *gravel*, *sand*, *silt*, or *clay*, depending on the predominant size of particles within the soil.

**Gravels** are pieces of rocks with occasional particles of quartz, feldspar, and other minerals.

**Sand** particles are made of mostly quartz and feldspar

**Silts** are the microscopic soil fractions that consist of very fine quartz grains and some flake-shaped particles that are fragments of micaceous minerals.

**Clays** are mostly flake-shaped microscopic and submicroscopic particles of mica



In general: Soil may be divided into two main classes

1- Coarse-grained or non-cohesive or cohesionless soils (Gravel and Sand)

- Excellent foundation material for supporting structures and roads.
- The best embankment material.
- The best backfill material for retaining walls.
- Might settle under vibratory loads or blasts.
- Dewatering can be difficult due to high permeability.
- If free draining does not frost susceptible

2- Fine-grained or cohesive soils (silt and clay)

- Very often, possess low shear strength.
- Plastic and compressible.
- Loses part of shear strength upon wetting.
- Loses part of shear strength upon disturbance.
- Shrinks upon drying and expands upon wetting.
- Very poor material for backfill.
- Poor material for embankments.
- Practically impervious.
- Clay slopes are prone to landslides.

## **2.3 Description of Individual Soil Particles**

### **2.3.1 Particle size characteristic**

To describe soils by their particle size, several organizations have developed particle-size classifications. The table below shows the particle size classifications developed by the **Massachusetts Institute of Technology (MIT)**, the **U.S. Department of Agriculture**, the **American Association of State Highway and Transportation Officials (AASHTO)**, and the **U.S. Army Corps of Engineers** and **U.S. Bureau of Reclamation**.

In table below, the **MIT** system is presented for illustration purposes only. This system is important in the history of the development of the size limits of particles present in soils; however, the **Unified Soil Classification System (USCS)** is now almost universally accepted and has been adopted by the American Society for Testing and Materials (**ASTM**). The figure below shows the size limits in a

graphic form.

Particle-Size Classifications				
Name of organization	Grain size (mm)			
	Gravel	Sand	Silt	Clay
1. Massachusetts Institute of Technology (MIT)	>2	2 to 0.06	0.06 to 0.002	<0.002
2. U.S. Department of Agriculture (USDA)	>2	2 to 0.05	0.05 to 0.002	<0.002
3. American Association of State Highway and Transportation Officials (AASHTO)	76.2 to 2	2 to 0.075	0.075 to 0.002	<0.002
4. Unified Soil Classification System 5. U.S. Army Corps of Engineers, 6. U.S. Bureau of Reclamation, 7. American Society for Testing and Materials)	76.2 to 4.75	4.75 to 0.075	Fines (i.e., silts and clays) <0.075	

Note: Sieve openings of 4.75 mm are found on a U.S. No. 4 sieve; 2-mm openings on a U.S. No. 10 sieve; 0.075-mm openings on a U.S. No. 200 sieve.

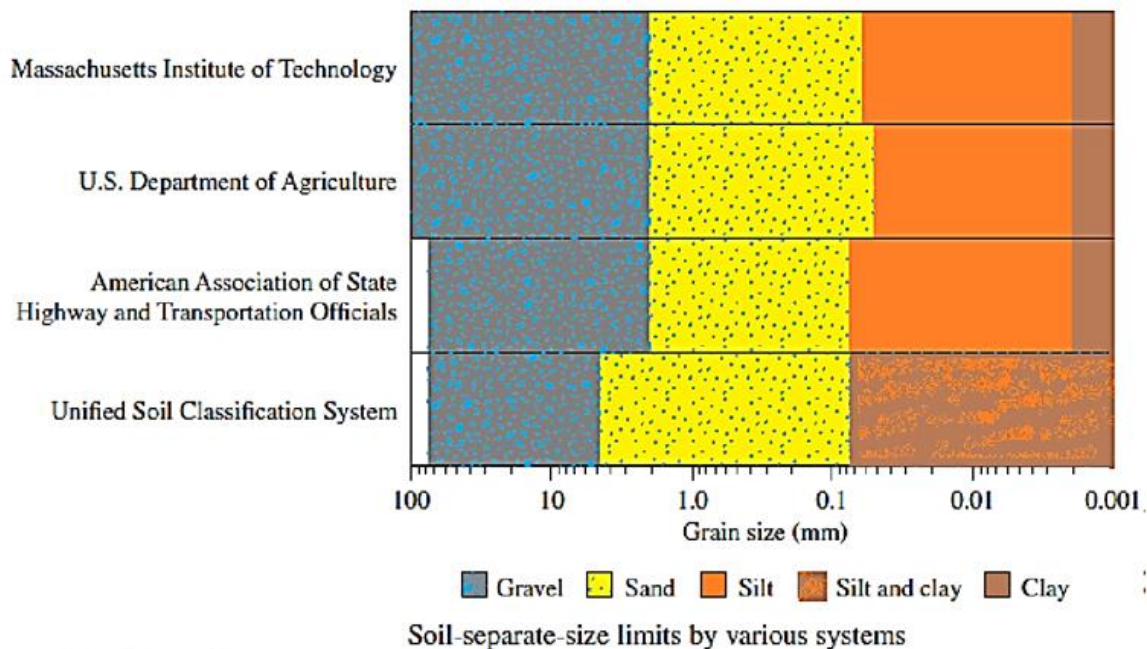

According to MIT:

Coarse-grained soils: Boulders > 300mm

Cobble 150-300mm

Gravel 2-150mm

Sand 0.06- 2 mm

















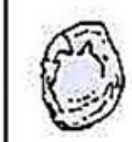

Fine –grained soil: silt 0.002-0.06 mm

Clay < 0.002

2.2.1 Particle shape

Equal-dimension, sphere, blade, rod, disk, flaky, and needle

2.2.2 Degree of roundness

						<b>High Sphericity</b>	
							<b>Medium Sphericity</b>
							<b>Low Sphericity</b>
<b>Very Angular</b>	<b>Angular</b>	<b>Sub- Angular</b>	<b>Sub- Rounded</b>	<b>Rounded</b>	<b>Well Rounded</b>		

### 2.2.1 Surface texture

Dull or polished and smooth or rough

### 2.2.2 Soil Color

- gray
- yellow
- brown
- red
- blue etc.



Soil color is influenced by the amount of proteins present in the soil. Yellow or red soil indicates the presence of iron oxides. Dark brown or black color in soil indicates that the soil has a high organic matter content. Wet soil will appear darker than dry soil.

### 2.3.2 Composition of a soil particle

The nature and arrangement of the atoms in a soil particle (composition) have a significant influence on engineering properties of soil (permeability, strength, compaction, and stress transmission of soil)

In general, the soil atoms classified as silicates, carbonates, phosphates, and oxides. The most important are the silicate minerals which accounts for 90% of the total soil in the world.

### 2.4 Clay Minerals

Clay minerals are complex aluminum silicates composed of two basic units:

#### 1. **Silica Tetrahedron:**

Each tetrahedron unit consists of four oxygen atoms surrounding a silicon atom. The combination of tetrahedral silica units gives a silica sheet. Three oxygen atoms at the base of each tetrahedron are shared by neighboring tetrahedral.

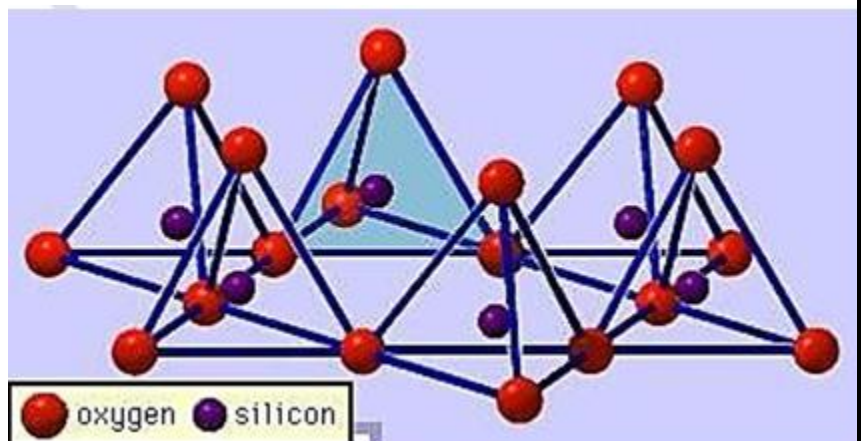



## 2. Alumina octahedron

The octahedral units consist of six hydroxyls surrounding an aluminum atom, and the combination of the octahedral aluminum hydroxyl units gives an octahedral sheet. (This also is called a gibbsite sheet)

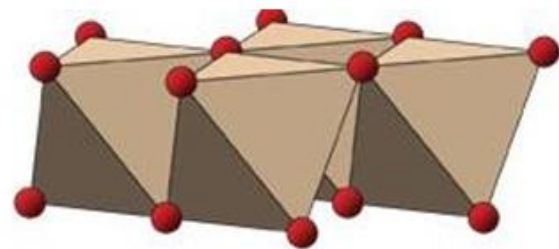
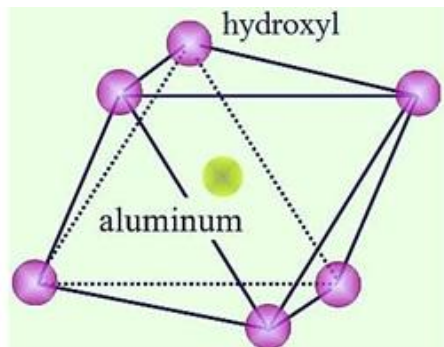

Alumina octahedra

Sometimes magnesium replaces the aluminum atoms in the octahedral units; in this case, the octahedral sheet is called a brucite sheet.

In a silica sheet, each silicon atom with a positive charge of four is linked to four oxygen atoms with a total negative charge of eight. However, each oxygen atom at the base of the tetrahedron is linked to two silicon atoms. This means that the top oxygen atom of each tetrahedral unit has a negative charge of one to be counterbalanced. When the silica sheet is stacked over the octahedral sheet, these oxygen atoms replace the hydroxyls to balance their charges.

Three important clay minerals,

**Kaolinite** consists of repeating layers of elemental silica- gibbsite sheets, as shown in

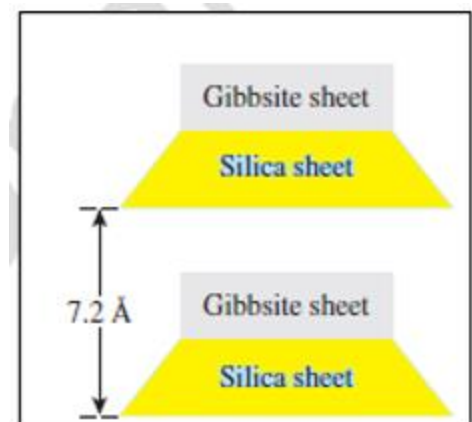

the figure and is about 7.2 Å thick. In this clay, the bonding is through electrical bonds and resists entering water between the layers thus the clay has medium viscosity and high strength and low swelling

**Montmorillonite** has a structure similar to that of illite, that is, one gibbsite sheet sandwiched between two silica sheets. In montmorillonite, there is the isomorphous substitution of magnesium and iron for aluminum in the octahedral sheets. Potassium ions are not present as in illite, and a large amount of water is attracted to the space between the layers. This clay has low resists for water entering thus the clay has medium viscosity and low strength and high swelling  
 The **illite** layers are bonded by potassium ions. The negative charge to balance the potassium ions comes

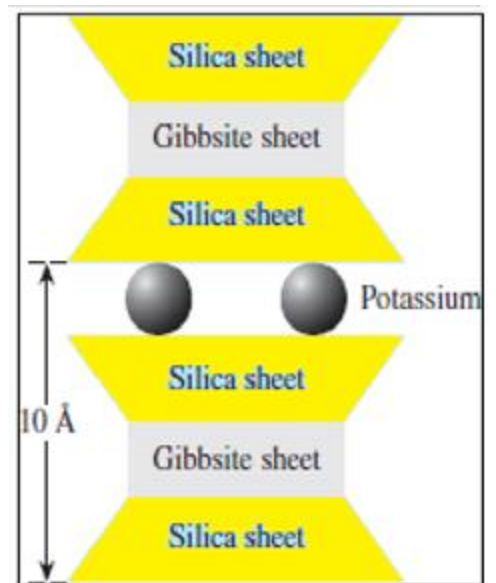
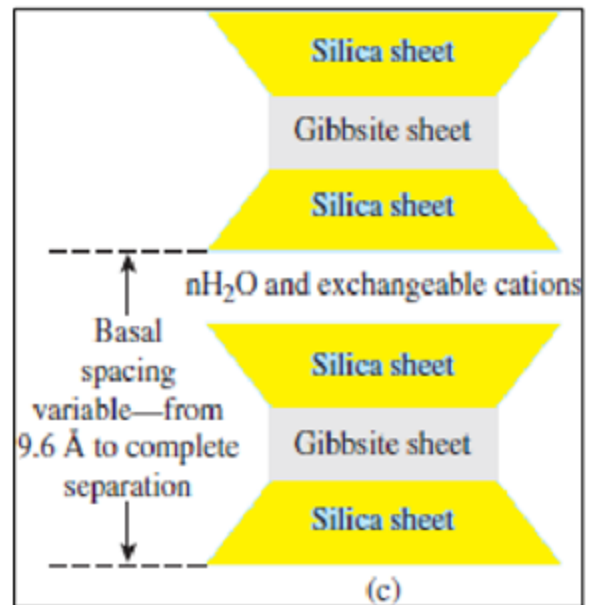

from the substitution of aluminum for some silicon in the tetrahedral sheets. In dry clay, the negative charge is balanced by exchangeable cations like  $\text{Ca}^{+2}$ ,  $\text{Mg}^{+2}$ ,  $\text{Na}^{+}$ , and  $\text{K}^{+}$  surrounding the particles being held by electrostatic attraction. When water is added to clay, these cations and a few anions float around the clay particles. This configuration is referred to as a diffuse double layer.

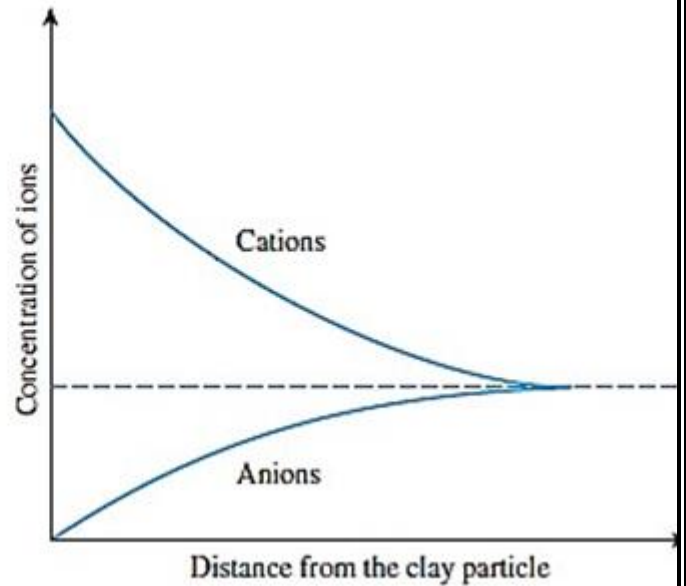
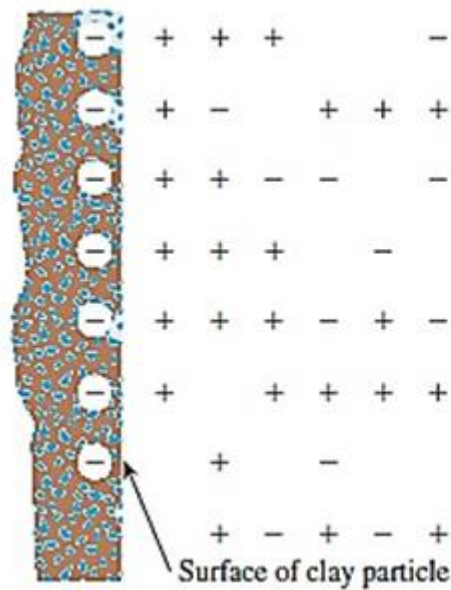

**2.2**  
Structure of Compacted Clay Soil

If the clay is compacted with a low moisture content, the diffuse double layers of ions surrounding the clay particles cannot be fully developed; hence, the inter-particle repulsion is reduced. This reduced repulsion results in a more random particle orientation and a lower dry unit weight.

When the moisture content of compaction is increased, the diffuse double layers around the particles expand, which increases the repulsion between the clay particles and gives a flocculation

structure

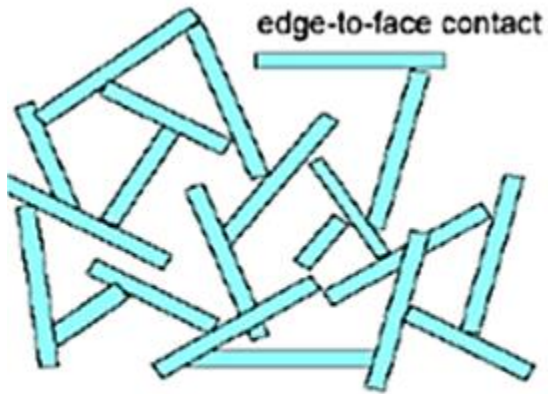

*Flocculated*

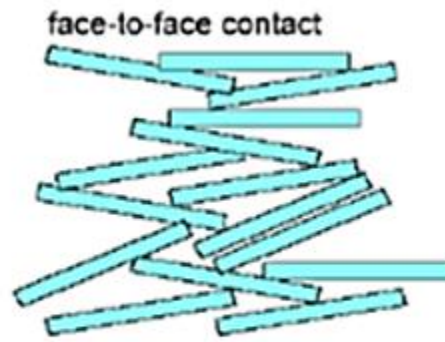

*Dispersed*

## Homework Chapter (2)

- 1 For a given soil, show that

$$\gamma_{\text{sat}} = n \left( \frac{1 + w_{\text{sat}}}{w_{\text{sat}}} \right) \gamma_w$$

- 2 For a given soil, show that

$$e = \frac{\gamma_{\text{sat}} - \gamma_d}{\gamma_d - \gamma_{\text{sat}} + \gamma_w}$$

- 3 For a given soil, show that

$$w_{\text{sat}} = \frac{n\gamma_w}{\gamma_{\text{sat}} - n\gamma_w}$$

- 4 The moist weight of  $2.83 \times 10^{-3} \text{ m}^3$  of soil is  $55.5 \times 10^{-3} \text{ kN}$ . If the moisture content is 14% and the specific gravity of soil solids is 2.71, determine the following:
- Moist unit weight
  - Dry unit weight
  - Void ratio
  - Porosity
  - Degree of saturation
  - Volume occupied by water
- 5 The moist unit weight of a soil is  $19.2 \text{ kN/m}^3$ . Given that  $G_s = 2.69$  and  $w = 9.8\%$ , determine:
- Void ratio
  - Dry unit weight
  - Degree of saturation
- 6 Refer to Problem 3. Determine the weight of water, in kN, to be added per cubic meter ( $\text{m}^3$ ) of soil for
- 90% degree of saturation
  - 100% degree of saturation
- 7 Undisturbed soil sample was collected from the field in steel Shelby tubes for laboratory evaluation. The tube sample has a diameter of 71 mm, length of 558 mm, and a moist weight of  $42.5 \times 10^{-3} \text{ kN}$ . If the oven-dried weight was  $37.85 \times 10^{-3} \text{ kN}$ , and  $G_s = 2.69$ , calculate the following:
- Moist unit weight
  - Field moisture content
  - Dry unit weight
  - Void ratio
  - Degree of saturation
- 8 When the moisture content of a soil is 26%, the degree of saturation is 72%, and the moist unit weight is  $16.98 \text{ kN/m}^3$ . Determine:
- Specific gravity of soil solids
  - Void ratio
  - Saturated unit weight

- 9 For a given soil, the following are known:  $G_s = 2.74$ , moist unit weight,  $\gamma = 20.6 \text{ kN/m}^3$ , and moisture content,  $w = 16.6\%$ . Determine:
- Dry unit weight
  - Void ratio
  - Porosity
  - Degree of saturation
- 10 Refer to Problem 9. Determine the weight of water, in kN, to be added per cubic meter ( $\text{m}^3$ ) of soil for
- 90% degree of saturation
  - 100% degree of saturation
- 11 The moist density of a soil is  $1750 \text{ kg/m}^3$ . Given  $w = 23\%$  and  $G_s = 2.73$ , determine:
- Dry density
  - Porosity
  - Degree of saturation
  - Mass of water, in  $\text{kg/m}^3$ , to be added to reach full saturation.
- 12 For a moist soil, given the following:  $V = 7.08 \times 10^{-3} \text{ m}^3$ ;  $W = 136.8 \times 10^{-3} \text{ kN}$ ;  $w = 9.8\%$ ;  $G_s = 2.66$ . Determine:
- Dry unit weight
  - Void ratio
  - Volume occupied by water
- 13 For a given soil,  $\rho_d = 1800 \text{ kg/m}^3$  and  $n = 0.3$ . Determine:
- Void ratio
  - Specific gravity of soil solids
- 14 The moisture content of a soil sample is 17% and the dry unit weight is  $16.51 \text{ kN/m}^3$ . If  $G_s = 2.69$ , what is the degree of saturation?
- 15 For a given soil,  $w = 18.2\%$ ,  $G_s = 2.67$ , and  $S = 80\%$ . Determine:
- Moist unit weight in  $\text{kN/m}^3$
  - Volume occupied by water
- 16 The degree of saturation of a soil is 55% and the moist unit weight is  $16.66 \text{ kN/m}^3$ . When the moist unit weight increased to  $17.92 \text{ kN/m}^3$ , the degree of saturation increased to 82.2%. Determine:
- $G_s$
  - Void ratio

# **CHAPTER THREE**

## **SOIL Classification**

### **Lecture Notes**

### 3.1 Introduction

**Soil classification** is a separation of soil into classes or groups each having similar characteristics and potentially similar behavior. A classification for engineering purposes should be based mainly on mechanical properties, e.g. permeability, stiffness, strength. The classification to which a soil belongs can be used in its description.

In general, there are two major categories into which the classification systems can be grouped.

1. The textural classification is based on the particle-size distribution of the percent of gravel, sand, silt, and clay size fractions present in a given soil. Such as ***Massachusetts Institute of Technology classification system (M.I.T classification)*** and the ***U.S. Department of Agriculture.***
2. The other major category is based on the engineering behavior of soil and takes into consideration the particle-size distribution and the plasticity (i.e., liquid limit and plasticity index). Under this category, there are two major classification systems in extensive use now:
  - a. ***The American Association of State Highway and Transportation classification system (AASHTO), and***
  - b. ***The Unified classification system (USCS).***

### 3.2 Mechanical Analysis of Soil

The mechanical analysis is the determination of the size range of particles present in the soil, expressed as a percentage of the total dry weight. Two methods are used to find the particle-size distribution of soil:

- (1) Sieve analysis—for particle sizes larger than 0.075 mm in diameter, and
- (2) hydrometer analysis—for particle sizes smaller than 0.075 mm in diameter.



### 3.2.1 Sieve Analysis

Sieve analysis consists of shaking the soil sample through a set of sieves that have progressively smaller openings. U.S. standard sieve numbers and the sizes of openings are given in Table below. The smallest-sized sieve that should be used for this type of test is the U.S. No. 200 sieve

For gravel soil, the current size designation for U.S sieve is:

100.0 mm	37.5 mm	12.5 mm
75.0 mm	31.5 mm	9.5 mm
63.0 mm	25.0 mm	8.0 mm
50.0 mm	19.0 mm	6.3 mm
45.0 mm	16.0 mm	

For sandy soils, the designation used number, i.e. No. 4 as shown in Table

U.S. Standard Sieve Sizes

Sieve no.	Opening (mm)	Sieve no.	Opening (mm)
4	4.75	35	0.500
5	4.00	40	0.425
6	3.35	50	0.355
7	2.80	60	0.250
8	2.36	70	0.212
10	2.00	80	0.180
12	1.70	100	0.150
14	1.40	120	0.125
16	1.18	140	0.106
18	1.00	170	0.090
20	0.850	200	0.075
25	0.710	270	0.053
30	0.600		

Other contraries may use a different size. In addition, some use sieve No. 270 (0.053 mm), No. 325 (0.045 mm), and No. 400 (0.038 mm).

Once the percent finer for each sieve is calculated, then are plotted on semi logarithmic graph paper with percent finer as ordinary scale, and sieve opening size as the abscissa (logarithmic scale).

This plot is referred to as the particle-size distribution curve son

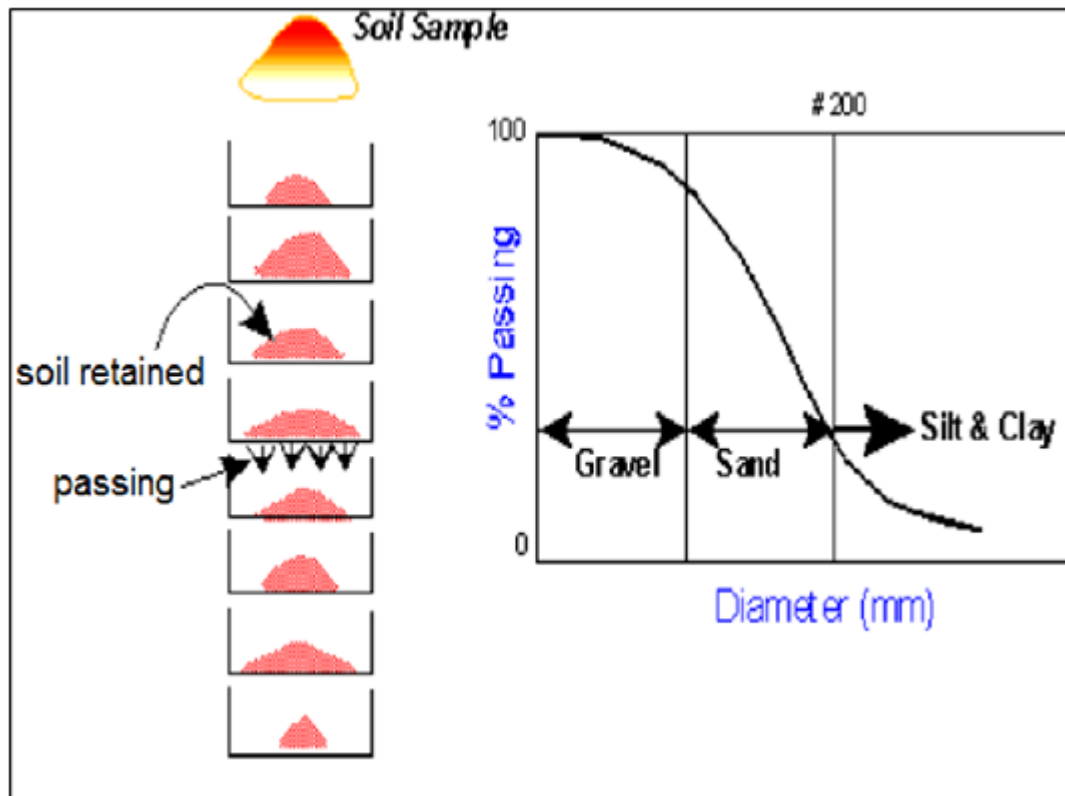

### 3.2.2. Hydrometer analysis

Is based on the principle of sedimentation of soil grains in water. When a soil specimen is dispersed in water, the particles settle at different velocities, depending on their shape, size, weight, and the viscosity of the water. For simplicity, it is assumed that all the soil particles are spheres and that Stokes' law can express the velocity of soil particles. Used for soil particles less than 0.075mm, (U.S. No. 200 sieve)

### 3.3 M.I.T Soil Classification

MIT Soil classification is the classification system devised by Massachusetts Institute of Technology, the USA for dividing soil into different classes. In this classification, the particles larger than 200 mm will be considered as boulders and larger 200 is cobble. The gravel range from (60 mm to 2 mm) and sand

between (2.0 mm to 0.06) and silt range from (0.06 mm to 0.002 mm). smaller than this is clay. Also, each type of soil subdivided to coarse, medium and fine).

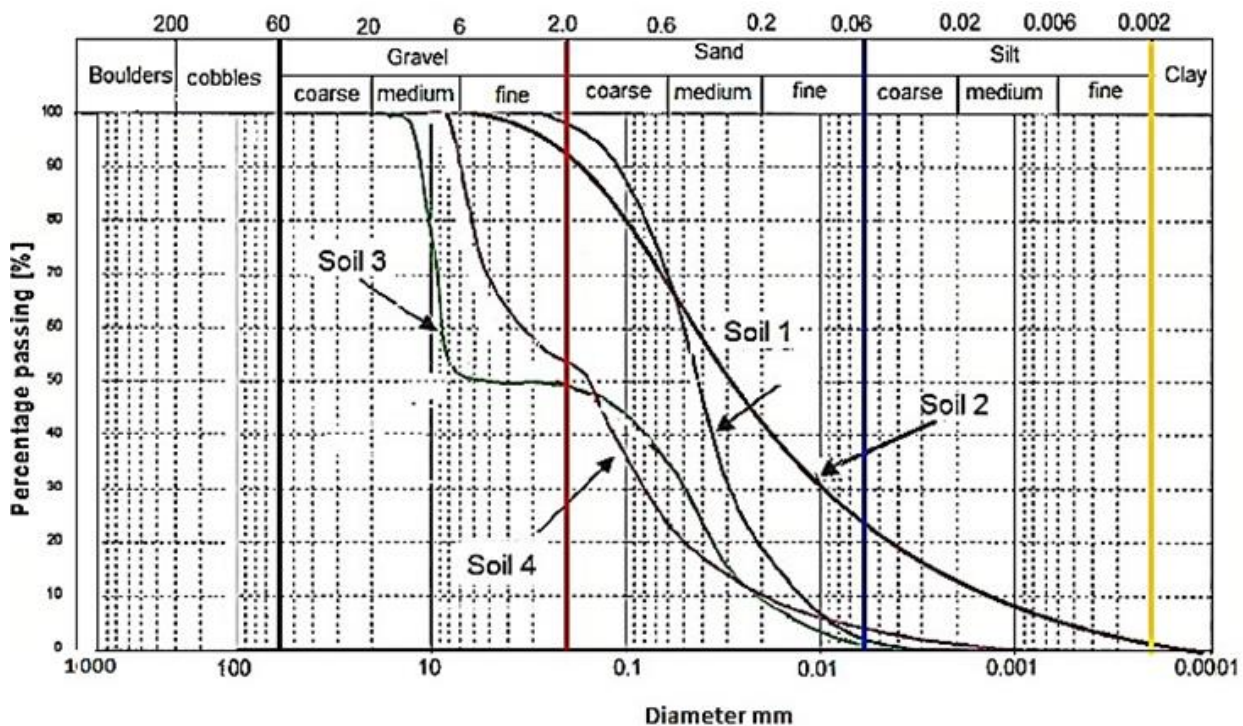

### Example (3.1)

Classify the soils shown in figure above according to M.I.T classification

### Solution

Soil 1

Soil 2

Soil		percentage	Soil		percentage
Boulders		0	Boulders		0
Cobbles		0	Cobbles		0
Gravel 2	Coarse	0	Gravel 8	Coarse	0
	Medium	0		Medium	0
	Fine	2		Fine	8
Sand 96	Coarse	28	Sand 69	Coarse	24
	Medium	51		Medium	25
	Fine	17		Fine	20
Silt 2	Coarse	2	Silt 22	Coarse	10
	Medium	0		Medium	8
	Fine	0		Fine	4
clay		0	clay		1

Soil (1) classified as sandy soil,

Soil (2) classified as Sandy silty gravel

Soil 3

Soil 4

Soil 3			Soil 4		
Soil		percentage	Soil		percentage
Boulders		0	Boulders		0
Cobbles		0	Cobbles		0
Gravel 50	Coarse	0	Gravel 45	Coarse	0
	Medium	50		Medium	10
	Fine	0		Fine	35
Sand 50	Coarse	15	Sand 51	Coarse	32
	Medium	25		Medium	12
	Fine	10		Fine	7
Silt 0	Coarse	0	Silt 4	Coarse	3
	Medium	0		Medium	1
	Fine	0		Fine	0
clay		0	clay		0

## 3.3

Soil (3) classified as gravelly sand

Soil (4) classified as sandy gravel

### 3.4 Textural Classification

The textural classification systems developed by the U.S. Department of Agriculture (USDA). This classification method is based on the particle-size limits as described under the USDA system; that is

- Sand size: 2.0 to 0.05 mm in diameter
- Silt-size: 0.05 to 0.002 mm in diameter
- Clay size: smaller than 0.002 mm in diameter

The use of this chart can best be demonstrated by an example. If the particle-size distribution of soil (A) shows **30% sand**, **40% silt**, and **30% clay-size particles**, its textural classification can be determined by proceeding in the manner indicated by the arrows in Figure. This soil falls into the zone of **clay loam**.

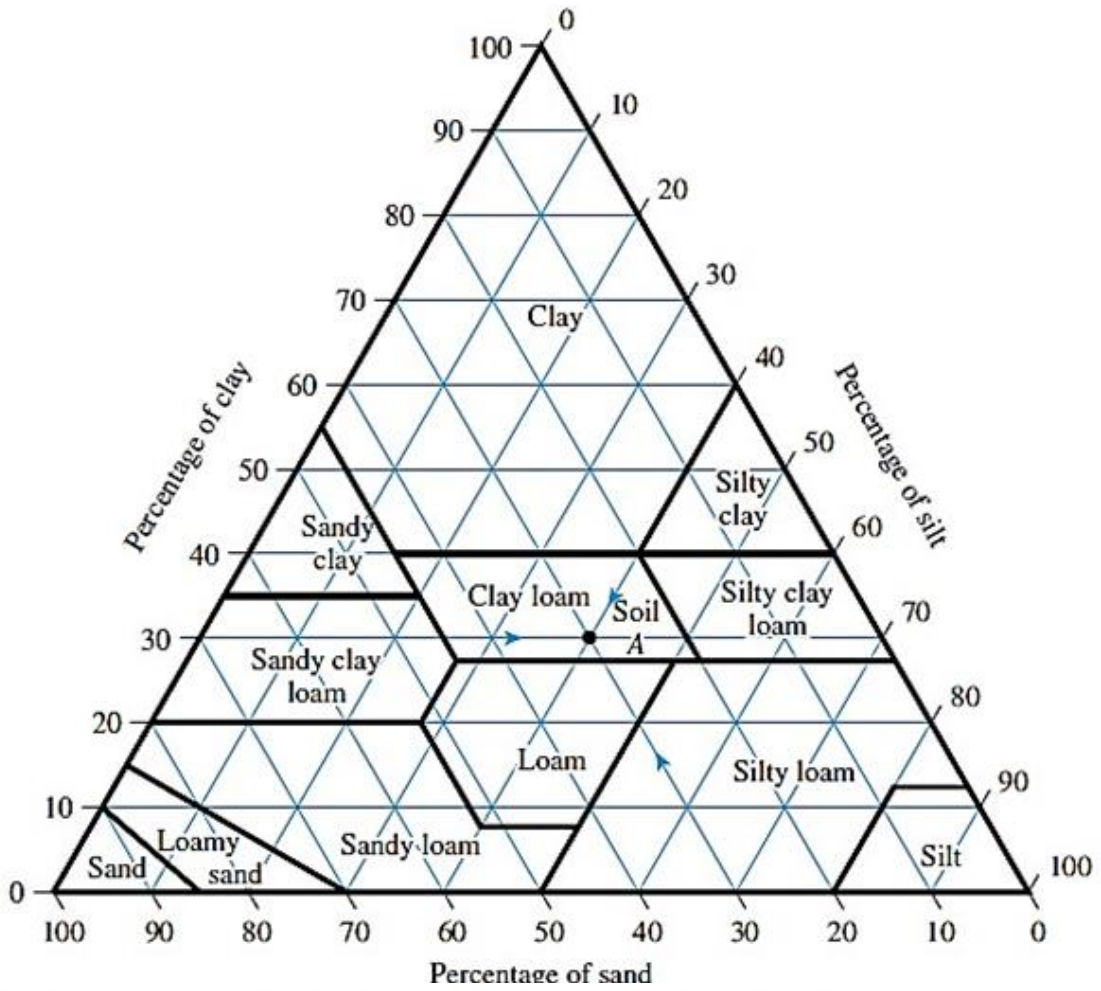

U.S. Department of Agriculture textural classification (*USDA*)

### Example (3.2)

Classify the following soil using the U.S. Department of Agriculture textural classification chart.

### Solution

From the figure, find the zone of each soil

Particle size distribution%			
Soil	Sand	Silt	Clay
A	20	20	60
B	55	5	40
C	45	35	20
D	50	15	35
E	70	15	15

Soil A is Clay

Soil B is

Sandy clay

Soil C is

Loam

Soil D is Sandy clay to Sandy clay loam Soil E is Sandy clay loam

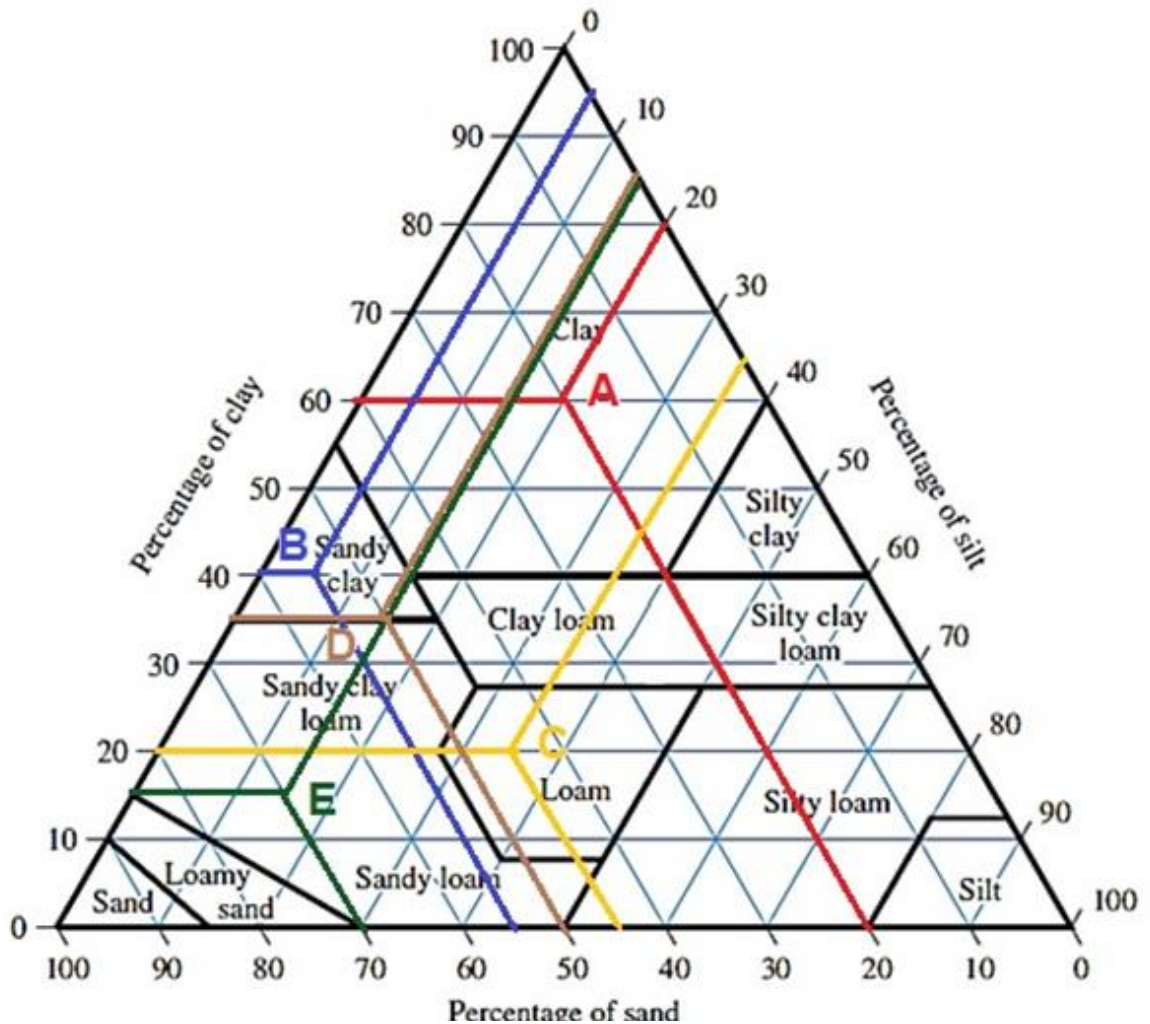

U.S. Department of Agriculture textural classification (USDA)

Note that this chart is based on only the fraction of the soil that passes through the No. 10 sieve. Hence, if the particle-size distribution of soil is larger than 2 mm in diameter, a correction will be necessary. The calculate modified percentages of sand, gravel, and silt as follows

$$\text{Modified \% sand} = \frac{\% \text{ sand}}{100 - \% \text{ gravel}} \times 100$$

$$\text{Modified \% silt} = \frac{\% \text{ silt}}{100 - \% \text{ gravel}} \times 100$$

$$\text{Modified \% clay} = \frac{\% \text{ clay}}{100 - \% \text{ gravel}} \times 100$$

### Example (3.3)

A soil has a particle-size distribution of 20% gravel, 10% sand, 30% silt, and 40% clay, the modified textural compositions are

$$\text{Sand size: } \frac{10 \times 100}{100 - 20} = 12.5\%$$

$$\text{Silt size: } \frac{30 \times 100}{100 - 20} = 37.5\%$$

$$\text{Clay size: } \frac{40 \times 100}{100 - 20} = 50.0\%$$

By the preceding modified percentages, the USDA textural classification is **clay**. However, because of the large percentage of gravel, it may be called **gravelly clay**.

*Several other textural classification systems are also used, but they are no longer useful for civil engineering purposes.*

### Example (3.4)

Classify the soils in Table shown according to USDA

#### Solution

Step 1: use the modification equation to find the new percentage

Particle size distribution %				
Soil	A	B	C	D
Gravel	12	18	0	12
Sand	25	31	15	22
Silt	32	30	30	26
Clay	31	21	55	40

$$\text{Modified \% sand} = \frac{\% \text{ sand}}{100 - \% \text{ gravel}} \times 100$$

$$\text{Modified \% silt} = \frac{\% \text{ silt}}{100 - \% \text{ gravel}} \times 100$$

$$\text{Modified \% clay} = \frac{\% \text{ clay}}{100 - \% \text{ gravel}} \times 100$$



Thus, the following table results:

**Step 2:** With the modified composition calculated, refer to Figure to determine the zone into which each soil falls. The results are as follows:

Particle size distribution %				
Soil	A	B	C	D
Sand	28.4	37.8	15	25
Silt	36.4	36.6	30	29.5
Clay	35.2	25.6	55	45.5

Soil (A) Gravelly

clay loam Soil (B)

Gravelly loam

Soil (C) Clay

Soil (D) Gravelly clay

Note: The word gravelly was added to the classification of soils A, B, and D because of the percentage of gravel present in each.

### **3.5 Classification by Engineering Behavior**

The textural classification of soil is relatively simple; it is based entirely on the particle-size distribution. The amount and type of clay minerals present in fine-grained soils dictate to a great extent their physical properties. Hence, the soils engineer must consider plasticity, which results from the presence of clay minerals, to interpret soil characteristics properly.

There are two more elaborate classification systems are commonly used by soils engineers. Both systems take into consideration the particle-size distribution and Atterberg limits. They are the **American**

Association of State Highway and Transportation Officials (AASHTO) classification system and the Unified Soil Classification System (USCS). The AASHTO classification system is used mostly by state and county highway departments. Geotechnical engineers prefer the Unified Soil Classification System.

### 3.6 Plasticity of Fine-Grained Soils

Plasticity is the ability of soil to undergo unrecoverable deformation at constant volume without cracking or crumbling. It is due to the presence of clay minerals or organic material.

#### Consistency limits (Atterberg limits):

Atterberg, a Swedish scientist, developed a method for describing the limit consistency of fine-grained soils by moisture content. These limits are a **liquid limit**, **plastic limit**, and **shrinkage limit**.

These limits are based on the concept that a fine-grained soil can exist in any four states depending on its water content

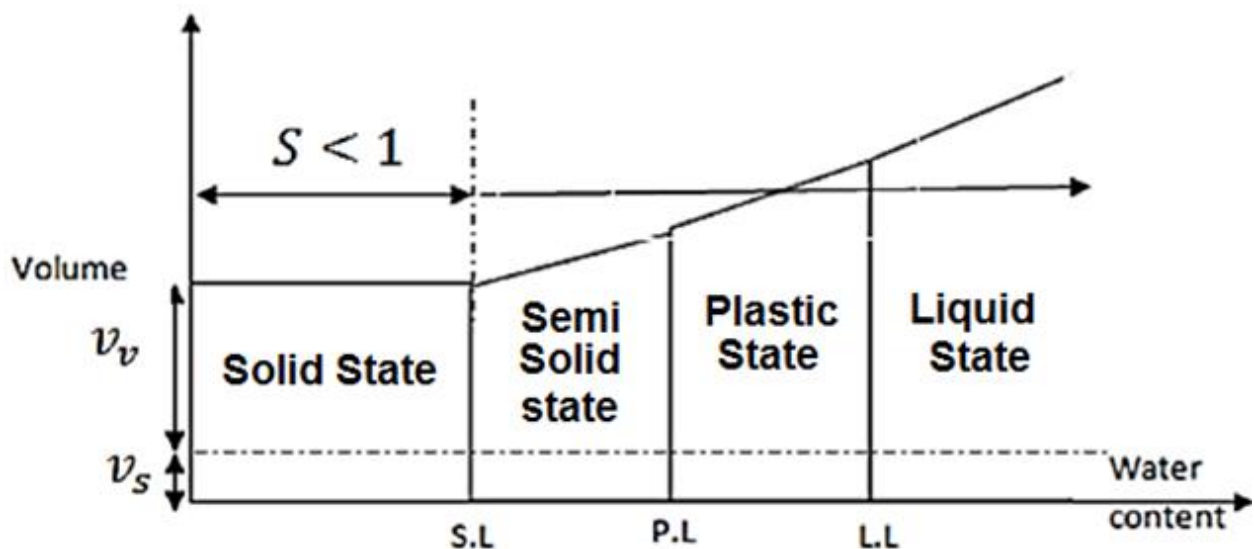

**1-Shrinkage Limit (S.L.):** The moisture contents in % at which the soil changes from semi-solid to solid state. It also can be considered as the minimum water content at which no decrease in soil volume

**2-Plastic Limit (P.L.):** The moisture contents in % at which the soil changes from plastic to a semi-solid state.

**3-Liquid limit (L.L):** is defined as the moisture content in percent at which the soil changes from liquid to plastic state.

**4-Plasticity Index (P.I.):** is the range in moisture content when the soil exhibited its plastic behavior:

$$P.I = L.L - P.L$$

#### Notes on Atterberg limits

1- Plasticity property is important because it describes the response of soil to change in moisture content

2- Water Content Significantly affects properties of Silty and Clayey soils (unlike sand and gravel)

- Strength decreases as water content increases
- Soils swell up when water content increases
- Fine-grained soils at very high water content possess properties similar to liquids semi-solid, plastic and liquid
- As the water content is reduced, the volume of the soil decreases and the soils become plastic
- If the water content is further reduced, the soil becomes semi-solid when the volume does not change

3- Atterberg limits are important to describe the consistency of fine-grained soils

- 4- The knowledge of the soil consistency is important in defining or classifying a soil type or predicting soil performance when used a construction material
- 5- A fine-grained soil usually exists with its particles surrounded by water. 6- The amount of water in the soil determines its state or consistency
- 7- Four states are used to describe the soil consistency; solid, semi-solid, plastic and liquid

The shrinkage limit tests are performed in the laboratory with a porcelain dish about 44 mm in diameter and about 12.7 mm high. The inside of the dish is coated with petroleum jelly and is then filled completely with wet soil. Excess soil standing above the edge of the dish is struck off with a straightedge. The mass of the wet soil inside the dish is recorded. The soil pat in the dish is then oven-dried. The volume of the oven-dried soil pat is determined by the displacement of mercury.

classified the plasticity index in a qualitative manner

<i>PI</i>	Description
0	Nonplastic
1–5	Slightly plastic
5–10	Low plasticity
10–20	Medium plasticity
20–40	High plasticity
>40	Very high plasticity

**5-Toughness Index** is the ratio of plasticity index to the flow index, which expresses the soil consistency in the plastic State.

$$T.I = \frac{P.I}{F.I}$$

The flow index is the slope of flow curve; it shows how close the clayey soil from the plastic state

**6-Liquidity Index (L.I)** is a relation between the natural moisture contents ( $\omega_n$ ) and (L.L.) and (P.L.) in form

$$LI = \frac{w_n - PL}{LL - PL} \quad \text{where } (w_n) \text{ is in situ moisture content of the soil}$$

L.I < 0;  $w_n < P.L \rightarrow$  Soil in semi or solid State

L.I = 0,  $w_n = P.L \rightarrow$  Soil at P.L

0 < L.I < 1:  $w_n < L.L \rightarrow$  Soil at plastic State

L.I = 1:  $w_n = L.L \rightarrow$  Soil at L.L

L.I > 1:  $w_n > L.L \rightarrow$  Soil at Liquid State.

### 7-Consistency Index (CI)

$$CI = \frac{LL - w_n}{LL - PI}$$

where  $w_n$  in situ moisture content.

If  $w_n$  is equal to the liquid limit, the consistency index

is zero. If  $w_n = PI$ , then  $CI = 1$ .

### 8-Activity (A)

$$A = \frac{PI}{(\% \text{ of clay-size fraction, by weight})}$$

### **Factors affecting the Atterberg Limits**

1. Shape and size of grains: As the grains size get smaller the plasticity increases while grains with flaky shape had more plasticity characteristics than other shapes.
2. The content of clay minerals: As the content of clay minerals increase the plasticity characteristics increase.

3. Type of clay minerals: Montmorillonite is more plasticity than illite; the Kaolinite is less clay mineral plasticity
4. Type of ions: The type of absorbed ions will affect the plasticity characteristics such as Na; Mg will give high plasticity while Ca will give low plasticity.
5. The content of organic matter: As the organic matter content increases the plasticity characteristics Increase.

**Example (3.5)**

The following data were obtained from the liquid test, and plastic limits is equal = 22 for a soil with  $\omega_n = 15\%$

No. of blows	Water content
13	42
22	40.6
41	39

**Solution**

Draw the flow curve & find the liquid limit.

The liquid limit = 40.1

$$P.I = L.L - P.L = 40.1 - 22 = 18.1$$

$$L.I = \frac{\omega_n - P.L}{P.I} = \frac{20 - 22}{18.1} = -0.11 < 1.0$$

$$C.I = \frac{L.L - \omega_n}{P.I} = \frac{40.1 - 22}{18.1} = 1$$

$$F.I = \frac{42 - 40.6}{\log 13 - \log 22} = -6.127$$

$$T.I = \frac{P.I}{F.I} = \frac{18.1}{-6.127} = -2.954$$

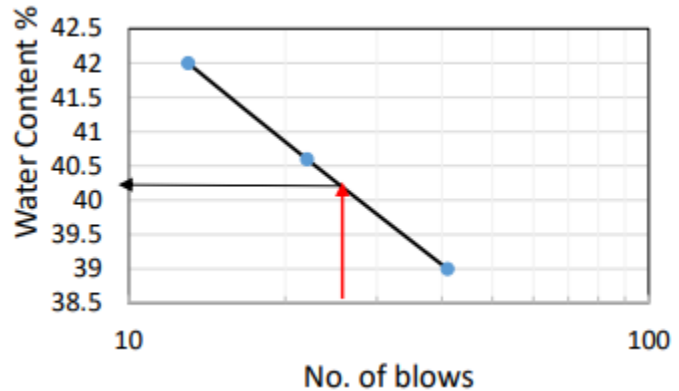

**Plasticity Chart** is the relationship of the plasticity index to the liquid limit of a wide variety of natural soils. By the test results, a proposed plasticity chart is shown in Figure. The important feature of this chart

is the empirical *A*-line that is given by the equation  $PI = 0.73(LL - 20)$ . An *A*-line separates the inorganic clays from the inorganic silts. Inorganic clay values lie above the *A*-line, and values for inorganic silts lie below the *A*-line. Organic silts plot in the same region (below the *A*-line and with *LL* ranging from 30 to 50) as the inorganic silts of medium compressibility. Organic clays plot in the same region as inorganic silts of high compressibility (below the *A*-line and *LL* greater than 50). The information provided in the plasticity chart is of great value and is the basis for the classification of fine-grained soils in the Unified Soil Classification System.

Note that a line called the *U*-line lies above the *A*-line. The *U*-line is approximately the upper limit of the relationship of the plasticity index to the liquid limit for any currently known soil. The equation for the *U*-line can be given as:

$$P.I = 0.9(L.L - 8)$$

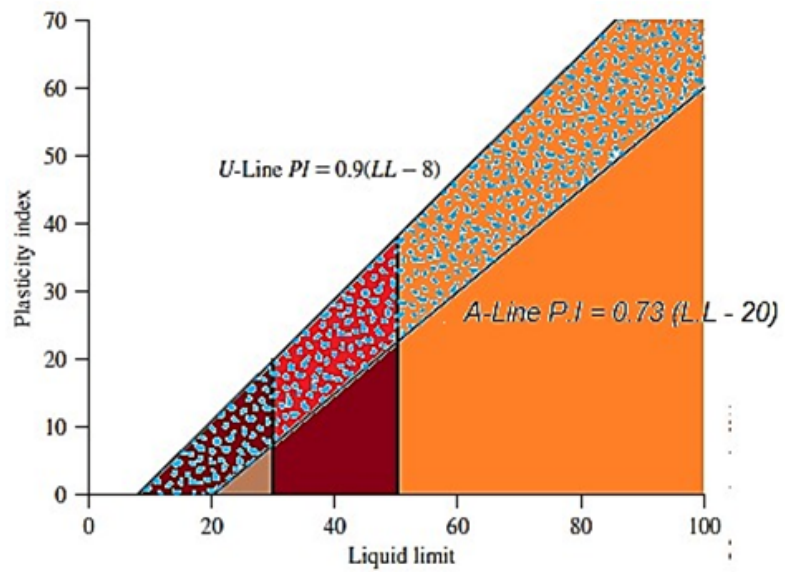

- Cohesionless soil
- Inorganic clays of low plasticity
- Inorganic silts of low compressibility
- Inorganic clays of medium plasticity
- Inorganic silts of medium compressibility and organic silts
- Inorganic clays of high plasticity
- Inorganic silts of high compressibility and organic clays



### Example (3.6)

A dry sample of soil having the following properties, L.L. = 55%, P.L. = 32%,  $G_s = 2.7$ ,  $e = 0.50$ . Find Shrinkage limit, dry density, dry unit weight, and air content at dry state.

#### Solution:

$$\text{Dry sample} \iff e_{\text{dry}} = e_{\text{shrinkage}} = 0.5$$

$$S.e_{s.L} = G_s \cdot \omega_c \text{ S.L.} \iff 1 * 0.5 = 2.7 * \text{S.L.} \iff \text{S.L.} = 18.52\%$$

$$\rho_d = \frac{G_s}{1+e} \rho_w = \frac{2.7}{1+0.5} * 1 = 1.8 \text{ g/m}^3$$

$$\gamma_{\text{dry}} = 1.8 * 9.81 = 17.66 \text{ kN/m}^3$$

$$\text{At dry state } S\% = 0 \iff A = n = e / (1+e) = 0.5 / (1+0.5) = 0.33 = 33.3\%$$

### Example (3.7)

A saturated soil sample has a volume of  $25 \text{ cm}^3$  at its L.L. if L.L. = 45%, P.L. = 30%, S.L. = 15%,  $G_s = 2.75$ . Find the min. volume the soil can attain.

#### Solution

The minimum volume occurs at S.L. or dry state.

$$v_t = v_v + v_s, v_s: \text{ is constant along all state.}$$

#### At L.L.

$$S.e_{L.L} = G_s \cdot \omega_c \text{ L.L.} \iff 1 * e_{L.L} = 2.75 * 0.45 \therefore e_{L.L} = 1.24$$

$$e = \frac{v_v}{v_s} = \frac{v_t - v_s}{v_s} = \frac{25 - v_s}{v_s} = 1.24$$

$$v_s = 11.161 \text{ cm}^3$$

#### At S.L

$$S.e_{S.L} = G_s \cdot \omega_c \text{ S.L.} \iff 1 * e_{S.L} = 2.75 * 0.15 \therefore e_{S.L} = 0.4125$$

$$e = \frac{v_v}{v_s} = \frac{v_v}{11.161} = 0.4125$$

$$\text{Min } v_v = 4.79$$

$$\text{Min. soil volume} = 4.79 + 11.161 = 15.95 \text{ cm}^3$$

### Example (3.8)

A sample of saturated clay had a volume of  $100 \text{ cm}^3$  and a mass of (0.2 kg). When completely dried at the volume of the sample was ( $85 \text{ cm}^3$ ) and its mass (0.160 kg). Find (a) Initial water content. (b) Shrinkage limit (c) Specific gravity Solution

$$\rho_t = \frac{M}{V} = \frac{200}{100} = 2 \text{ gm/cm}^3$$

$$2 = \frac{G_s + e}{1 + e} \rho_w = \frac{G_s + e}{1 + e} * 1 \dots \dots (1)$$

$$\omega_c = \frac{M_w}{M_s} = \frac{200 - 160}{160} = 0.25 = 25\%$$

$$S.e = G_s \cdot \omega_c \implies 1 * e = G_s * 0.25 \dots \dots (2)$$

$$\text{Solve (1) and (2)} \implies G_s = 2.67 \text{ and } e = 0.67$$

At dry state

$$\rho_{dry} = \frac{M_s}{V} = \frac{160}{85} = 1.88 \text{ gm/cm}^3$$

$$\rho_{dry} = 1.88 = \frac{G_s}{1 + e} \rho_w = \frac{2.67}{1 + e} * 1 \rightarrow e_{S.L} = 0.42$$

$$S.e_{S.L} = G_s \cdot \omega_{c.S.L} \implies 1 * 0.42 = 2.67 * \omega_{c.S.L}$$

$$\omega_{c.S.L} = 0.1573 = 15.73\%$$

### 3.7 Relative Density of Cohesionless Soil

It is the ratio of the actual density to the maximum possible density of the soil it is expressed in terms of void ratio.

$$R_D \text{ or } D_r \% = \frac{e_{max} - e_n}{e_{max} - e_{min}} * 100\%$$

or

$$D_r \% = \frac{\gamma_{dmax}}{\gamma_{dn}} * \frac{\gamma_{dn} - \gamma_{dmin}}{\gamma_{dmax} - \gamma_{dmin}} * 100\%$$

$e_{max}$ : maximum void ratio at the loosest condition

$e_{min}$ : minimum void ratio at the densest condition

$e_n$ : void ratio at the field or natural condition

$\gamma_{dmax}$ : maximum dry unit weight (at  $e_{min}$ )

$\gamma_{dmin}$ : minimum dry unit weight (at  $e_{max}$ )

$\gamma_{dn}$ : dry unit weight at field (at  $e_n$ )

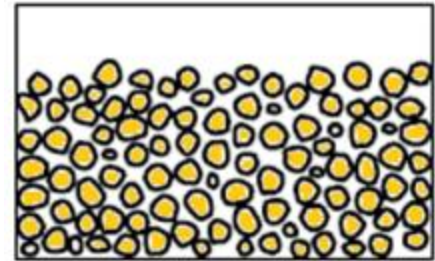

Loose soil

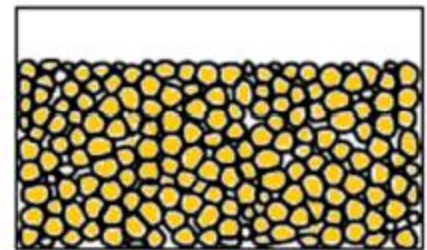

Dense Soil

Relative density	Description of soil
0 - 15	Very loose
15 - 35	Loose
35 - 65	Medium
65 - 85	Dense
85 - 100	Very dense

#### **Example (3.9)**

A granular soil with  $\gamma_{dn} = 16.9 \text{ kN/m}^3$ , if the relative density is 80%,  $\alpha_c = 10\%$

and  $G_s = 2.65$ . Find the dry unit weight in the loosest state and  $e_{max}$  if  $e_{min}$  is

0.45

#### **Solution:**

$$\gamma_{dn} = 16.9 = \frac{G_s}{1 + e_n} \gamma_w = \frac{2.65}{1 + e_n} * 9.81 \rightarrow e_n = 0.538$$

$$D_r \% = \frac{e_{max} - e_n}{e_{max} - e_{min}} * 100\%, 0.80 = \frac{e_{max} - 0.538}{e_{max} - 0.45} \rightarrow e_{max} = 0.89$$

Dry unit weight in the loosest state =  $\gamma_{dmin}$

$$\gamma_{dmin} = \frac{G_s}{1 + e_{max}} \gamma_w = \frac{2.65}{1 + 0.89} * 9.81 = 13.75 \text{ kN/m}^3$$

### **Example (3.10)**

A granular soil is compacted to the moist unit weight of 20.45 kN/m<sup>3</sup> at a moisture content of 18%. What is relative density of the compacted soil, if  $e_{max} = 0.85$ ,  $e_{min} = 0.42$  and  $G_s = 2.65$

### **Solution**

$$\gamma_t = \frac{G_s(1 + \omega_c)}{1 + e_n} \gamma_w = 20.45 = \frac{2.65 * (1 + 0.18)}{1 + e_n} * 9.81 \rightarrow e_n = 0.5$$

$$D_r \% = \frac{e_{max} - e_n}{e_{max} - e_{min}} * 100\% = \frac{0.85 - 0.50}{0.85 - 0.42} * 100\% = 81.4\%$$

## **3.8 AASHTO Classification System**

The AASHTO system of soil classification was developed in 1929 as the Public Road Administration classification system. (ASTM Designation D 3282; AASHTO method M145). The AASHTO classification is given in Table. The soil is classified into seven major groups: A-1 through A-7. Soils classified under groups A-1, A-2, and A-3, are granular materials of which 35% or less of the particles pass through the No. 200 sieve. Soils of which more than 35% pass through the No. 200 sieve are classified into groups A-4, A-5, A-6, and A-7. These soils are mostly silt and clay-type materials. This classification system is based on

the following criteria: 1. Grain size a. Gravel: fraction passing the 75-mm sieve and retained on the No. 10 (2-mm) U.S. Sieve b) Sand: the fraction is passing the No. 10 (2-mm) U.S. sieve and retained on the No. 200 (0.075-mm) U.S. Sieve c) Silt and clay: the fraction is passing the No. 200 U.S. Sieve 2. Plasticity: The term silty is applied when the fine fractions of the soil have a plasticity index of 10 or less. The term clayey is applied when the fine fractions have a plasticity index of 11 or more. 3. If cobbles and boulders (a size larger than 75 mm) are encountered, they are excluded from the portion of the soil sample from which classification is made. However, the percentage of such material is recorded. To classify a soil according to Table below, one must apply the test data from left to the right. By process of elimination, the first group from the left into which the experimental data fit is the correct classification. The figure shows a plot of the range of the liquid limit and the plasticity index for soils that fall into groups A-2, A-4, A-5, A-6, and A-7.

The equation gives the group index (GI) which useful in highway engineering for subgrade material

$$GI = (F_{200} - 35)[0.2 + 0.005(LL - 40)] + 0.01(F_{200} - 15)(PI - 10)$$

Where :

F<sub>200</sub> is percentage passing through the No. 200 sieve

L.L: liquid limit

P.I: plasticity index

The first term of Equation that is,  $(F_{200} - 35) [0.2 + 0.005(LL - 40)]$  which is the partial group index determined from the liquid limit. The second term that is:  $0.01(F_{200} - 15) (PI - 10)$  is the partial group index determined from the plasticity index. Following are some rules for determining the group index: 1. If Equation result yields a negative value for GI, it is taken as zero. 2. The group index

calculated from Equation is rounded off to the nearest whole number (for example,  $GI = 3.4$  is rounded off to 3;  $GI = 3.5$  is rounded off to 4). 3. There is no upper limit for the group index. 4. The group index of soils belonging to groups A-1-a, A-1-b, A-2-4, A-2-5, and A-3 is always 0. 5. When calculating the group index for soils that belong to groups A-2-6 and A-2-7, use the partial group index for PI, or

$$GI = 0.01(F_{200} - 15)(PI - 10)$$

In general, the quality of performance of soil as a subgrade material is inversely proportional to the group index

Classification of Highway Subgrade Materials

General classification	Granular materials (35% or less of total sample passing No. 200)						
	A-1			A-2			
Group classification	A-1-a	A-1-b	A-3	A-2-4	A-2-5	A-2-6	A-2-7
Sieve analysis (percentage passing)							
No. 10	50 max.						
No. 40	30 max.	50 max.	51 min.				
No. 200	15 max.	25 max.	10 max.	35 max.	35 max.	35 max.	35 max.
Characteristics of fraction passing No. 40							
Liquid limit				40 max.	41 min.	40 max.	41 min.
Plasticity index	6 max.		NP	10 max.	10 max.	11 min.	11 min.
Usual types of significant constituent materials	Stone fragments, gravel, and sand		Fine sand	Silty or clayey gravel and sand			
General subgrade rating	Excellent to good						

**General classification**

**Silt-clay materials  
(more than 35% of total sample passing No. 200)**

Group classification	A-4	A-5	A-6	A-7 A-7-5 <sup>a</sup> A-7-6 <sup>b</sup>
Sieve analysis (percentage passing)				
No. 10				
No. 40				
No. 200	36 min.	36 min.	36 min.	36 min.
Characteristics of fraction passing No. 40				
Liquid limit	40 max.	41 min.	40 max.	41 min.
Plasticity index	10 max.	10 max.	11 min.	11 min.
Usual types of significant constituent materials	Silty soils		Clayey soils	
General subgrade rating	Fair to poor			

<sup>a</sup>For A-7-5,  $PI \leq LL - 30$

<sup>b</sup>For A-7-6,  $PI > LL - 30$

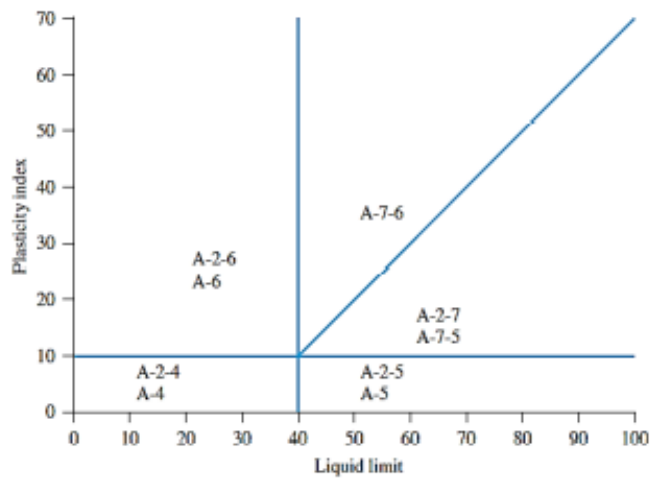

Range of liquid limit and plasticity index for soils in groups A-2, A-4, A-5, A-6, and A-7

### Example (3.11)

The results of the particle-size analysis of soil are as follows:

- Percent passing the No. 10 sieve = 42
  - Percent passing the No. 40 sieve = 35
  - Percent passing the No. 200 sieve = 20
- The liquid limit and plasticity index of the minus No. 40 fraction of the soil are 25 and 20, respectively. Classify the soil by the AASHTO system.

### Solution

Since 20% (less than 35%) of soil is passing No. 200 sieve, it is granular soil. Hence it can be A-1, A-2, or A-3. Refer to Table. Starting from the left of the table, the soil falls under A-1-b (see the table below).

Parameter	Specifications in Table	Parameters of the given soil
Percent passing sieve		
No. 10	—	
No. 40	50 max	35
No. 200	25 max	20
Plasticity index ( <i>PI</i> )	6 max	$PI = LL - PL = 25 - 20 = 5$

The group index of the soil is 0. So, the soil is A-1-b (0)

### Example (3.12)

Ninety-five percent of a soil passes through the No. 200 sieve and has a liquid limit of 60 and plasticity index of 40. Classify the soil by the AASHTO system.

### Solution

Ninety-five percent of the soil (which is  $\geq 36\%$ ) is passing through No. 200 sieve. So it is a silty-clay material. Now refer to Table. Starting from the left of the table, it falls under A-7-6 (see the table below).



Parameter	Specifications in Table	Parameters of the given soil
Percent passing No. 200 sieve	36 min.	95
Liquid limit ( <i>LL</i> )	41 min.	60
Plasticity index ( <i>PI</i> )	11 min.	40
<i>PI</i>	$> LL - 30$	$PI = 40 > LL - 30 = 60 - 30 = 30$

$$\begin{aligned}
 GI &= (F_{200} - 35) [0.2 + 0.005(LL - 40)] + 0.01(F_{200} - 15) (PI - 10) \\
 &= (95 - 35) [0.2 + 0.005(60 - 40)] + (0.01) (95 - 15) (40 - 10) \\
 &= 42
 \end{aligned}$$

So, the classification is A-7-6(42).

### 3.9 Unified Soil Classification System (USCS)

The original form of this system was proposed by Casagrande in 1942, then this system was revised in 1952. At present, it is used widely by engineers (ASTM Test Designation D-2487). The Unified classification system is presented in Table below.

This system classifies soils into two broad categories:

1. Coarse-grained soils that are gravelly and sandy in nature with less than 50% passing through the No. 200 sieve. The group symbols start with a prefix of **G** for **gravel** or **S** for **sandy** soil
2. Fine-grained soils are with 50% or more passing through the No. 200 sieve. The group symbols start with prefixes of **M**, for inorganic **silt** and **C** for inorganic **clay** or **O** for **organic** silts and clays. The symbol **Pt** is used for **peat, muck, and other highly organic soils**.
3. Other symbols used for the classification are:
  - a. W: well graded
  - b. P: poorly graded
  - c. L: low plasticity (liquid limit less than 50)
  - d. H: high plasticity (liquid limit more than 50)

For proper classification according to this system, some or all of the following information must be known:

1. Percent of gravel: that is, the fraction passing the 76.2 mm sieve and retained on the No. 4 sieve (4.75-mm opening)
  2. Percent of sand: that is, the fraction passing the No. 4 sieve (4.75-mm opening) and retained on the No. 200 sieve (0.075-mm opening)
- Percent of silt and clay: that is, the fraction finer than the No. 200 sieve (0.075-mm opening)

3. Uniformity coefficient ( $C_u$ ) and the coefficient of gradation ( $C_c$ )
4. Liquid limit and plasticity index of the portions of soil is passing the No. 40 sieve

The group symbols for coarse-grained gravelly soils are GW, GP, GM, GC, GC-GM, GW-GM, GW-GC, GP-GM, and GP-GC.

Similarly, the group symbols for fine-grained soils are CL, ML, OL, CH, MH, OH, CL-ML, and Pt.

More recently, ASTM designation D-2487 created an elaborate system to assign group names to soils. These names are summarized in Figures. In using these figures, one needs to remember that, in a given soil,

- Fine fraction \_ percent passing No. 200 sieve
- Coarse fraction \_ percent retained on No. 200 sieve
- Gravel fraction \_ percent retained on No. 4 sieve
- Sand fraction \_ (percent retained on No. 200 sieve)  
(percent retained on No. 4 sieve)

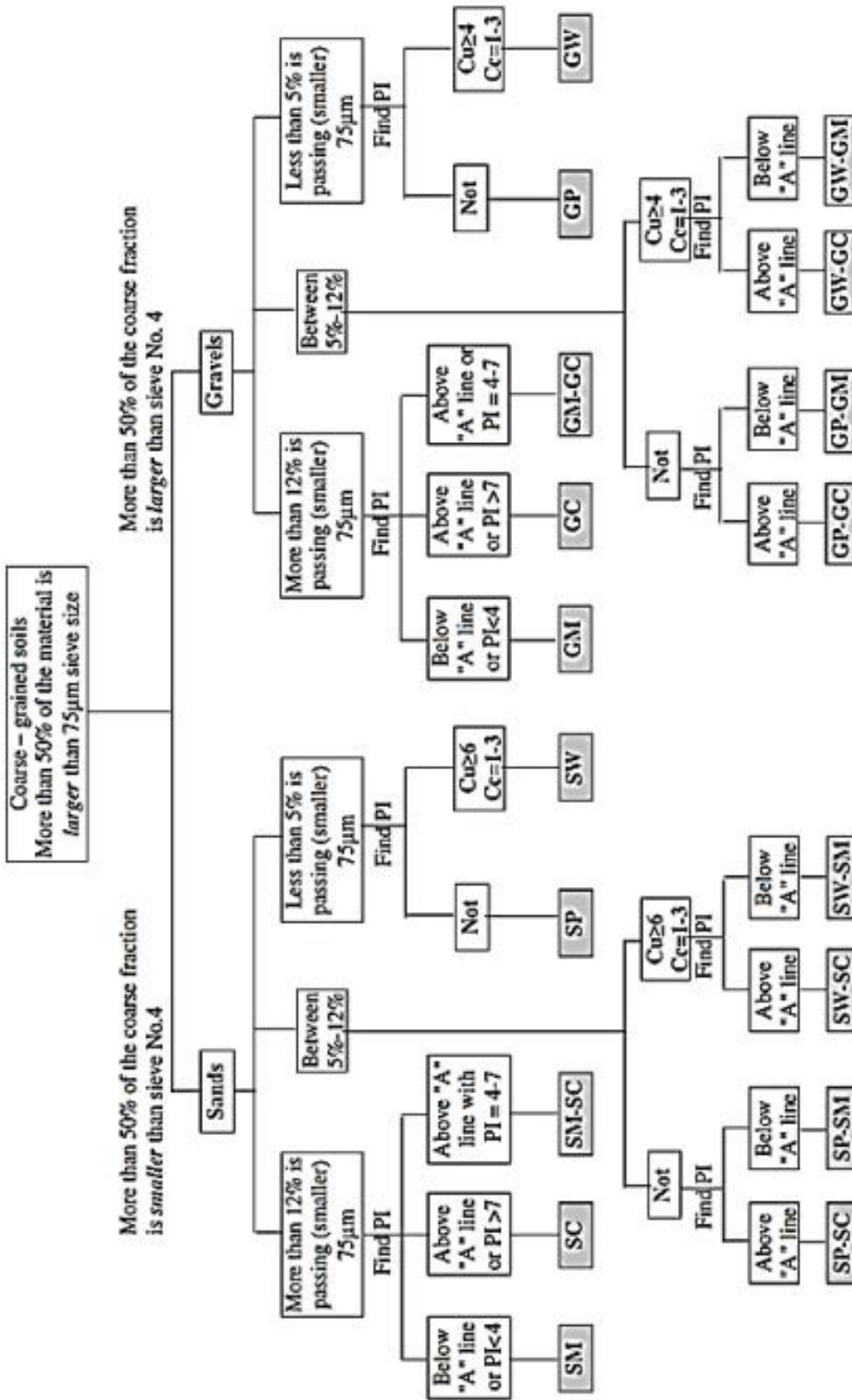

GW: Well graded gravels, gravel-sands mixtures, little or no fines GP: Poorly graded gravels gravel-sands mixtures, little or no fines GM: Silty gravels poorly graded gravel-sands-silt mixtures GC: Clayey gravels poorly graded gravel-sands clay mixtures SW: Well graded sands, gravel-sands, little or no fines SP: Poorly graded sands, gravel-sands, little or no fines SM: Silty sands, poorly graded sands-silt mixtures SC: Clayey sands, poorly graded sands clay mixtures

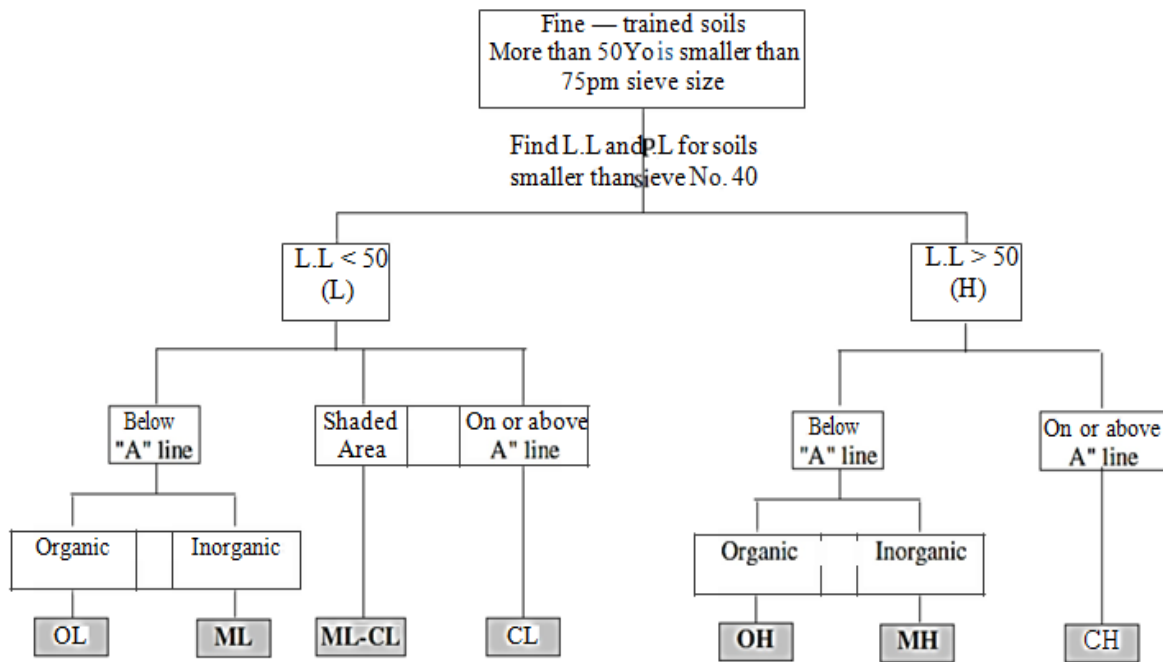

- OL: Organic silts and organic silt-clay of low plasticity.
- ML: Inorganic silts and very fine rock flour, silty or clayey fine sands with slight plasticity.
- CL: Inorganic clays of low or medium plasticity, gravelly clays, sandy clays, silty clays, lean clays.
- OH: Organic clays of medium to high plasticity.
- MH: Inorganic silts micaceous or diatomaceous fine sandy or silty soils, elastic silts.
- CH: Organic clays of high plasticity, fat clays.
- Pt: Peat and other highly organic soils

P.L: Plastic limit L.L: liquid limit  
 PI: Plasticity index = L.L - P.L

$$C_u = \frac{D_{60}}{D_{10}} \quad C_c = \frac{(D_{30})^2}{D_{10} \times D_{60}}$$

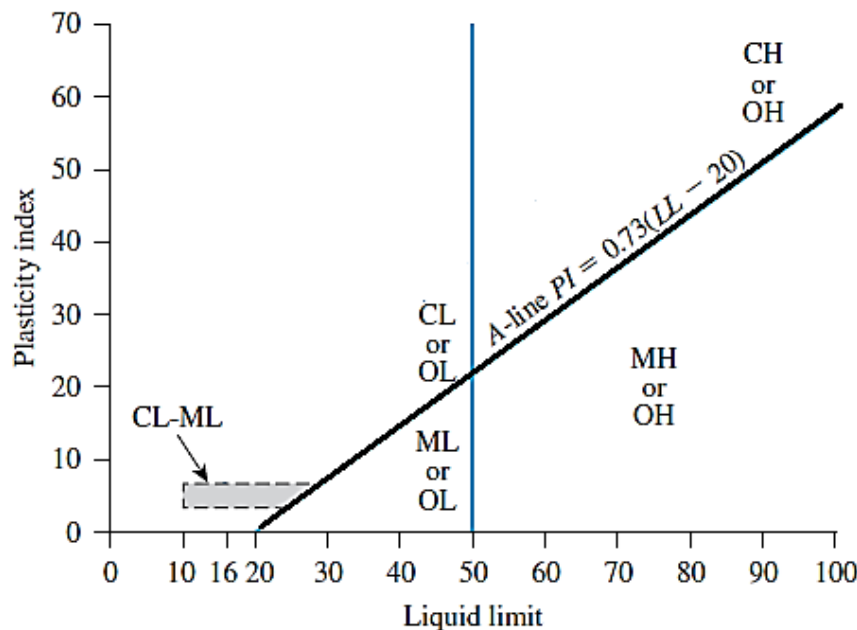
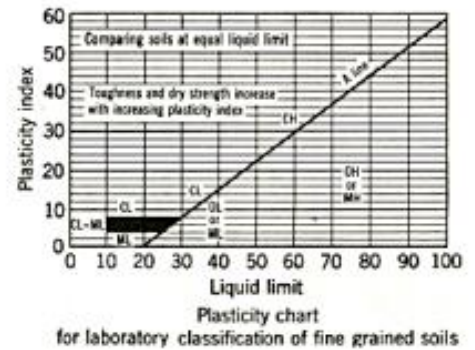

Plasticity chart

## Summary

It can be found that there are different methods of soil classification; each one has its limitation and measurements. The table below summarizes these methods.

		<b>Grain Size (mm)</b>						
		100	10	1	0.1	0.01	0.001	0.0001
Classification System								
Unified	Cobbles	Gravel		Sand		Fines (silt and clay)		
		75	4.75		.075			
AASHTO	Cobbles	Gravel		Sand		Silt	Clay	
		75	2		.05	.002		
MIT		Gravel		Sand		Silt	Clay	
			2		.06	.002		
ASTM		Gravel		Sand		Silt	Clay	
			4.75		.075	.002		
USDA	Cobbles	Gravel		Sand		Silt	Clay	
		75	2		.05	.002		

Group symbol	Group name
GW	< US sand — Well-graded gravel
	US sand — * Well-graded gravel with sand
GP	< US sand — * Poorly graded gravel
	ISO sand — Poorly graded gravel with sand
tsW-GM	<15% sand — * Well-graded gravel with silt
	ISO sand — * Well-graded gravel with silt and sand
GW-GC	<15% sand — Well-graded gravel with clay (or silty clay)
	≥15% sand — Well-graded gravel with clay and sand (or silty clay and sand)
GP-GM	< ISO sand — Poorly graded gravel with silt
	m ISO sand — * Poorly graded gravel with silt and sand
GP-GC	< US sand — Poorly graded gravel with clay (or silty clay)
	N ISO sand — Poorly graded gravel with clay and sand (or silty clay and sand)
GM	<15% sand — Silty gravel
	ISO sand — Silty gravel with sand
GC	<15% sand — Clayey gravel
	m 15% sand — Clayey gravel with sand
GC-GM	<15% sand — Silty clayey gravel
	≥15% sand — Silty clayey gravel with sand
SW	< 15% gravel — Well-graded sand
	m 15% gravel — Well-graded sand with gravel
SP	< 15% gravel — Poorly graded sand
	15% gravel — Poorly graded sand with gravel
SW-SM	< U% gravel — Well-graded sand with silt
	m U% gravel — Well-graded sand with silt and gravel
SW-SC	< U% gravel — Well-graded sand with clay (or silty clay)
	U% gravel — Well-graded sand with clay and gravel (or silty clay and gravel)
SP-SM	< U% gravel — Poorly graded sand with silt
	m 15% gravel — Poorly graded sand with silt and gravel
SP-SC	< 15% gravel — Poorly graded sand with clay (or silty clay)
	15% gravel — Poorly graded sand with clay and gravel (or silty clay and gravel)
SM	<15% gravel — Silty sand
	≥15% gravel — Silty sand with gravel
SC	< 15% gravel — Clayey sand
	m 15% gravel — Clayey sand with gravel
SC-SM	< 15% gravel — Silty clayey sand
	15% gravel — Silty clayey sand with gravel

Flowchart group names for gravelly and sandy soil {Source: From "Annual Book of ASTM Standards, 04.08." Copyright ASTM INTERNATIONAL. Reprinted with permission.}

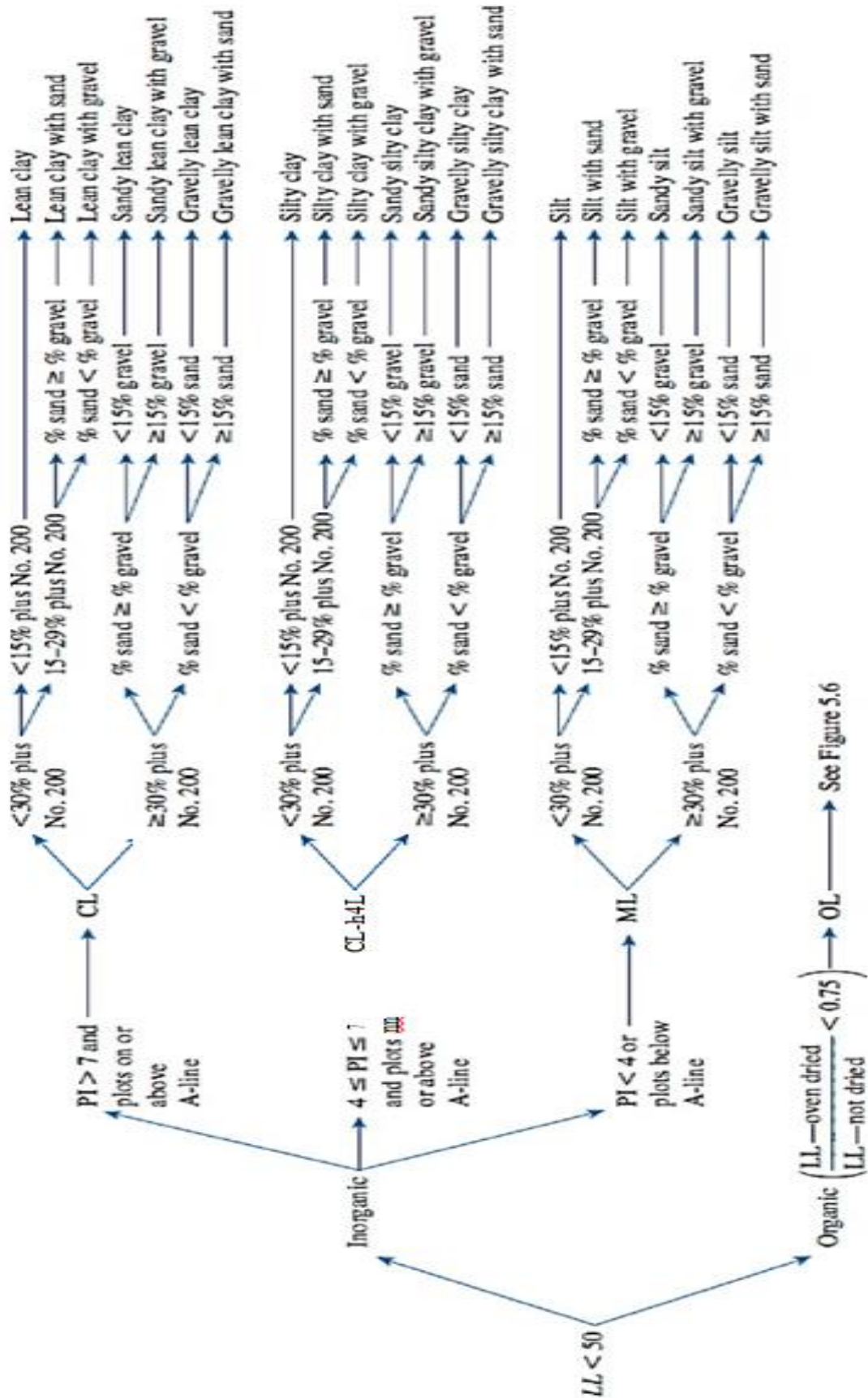



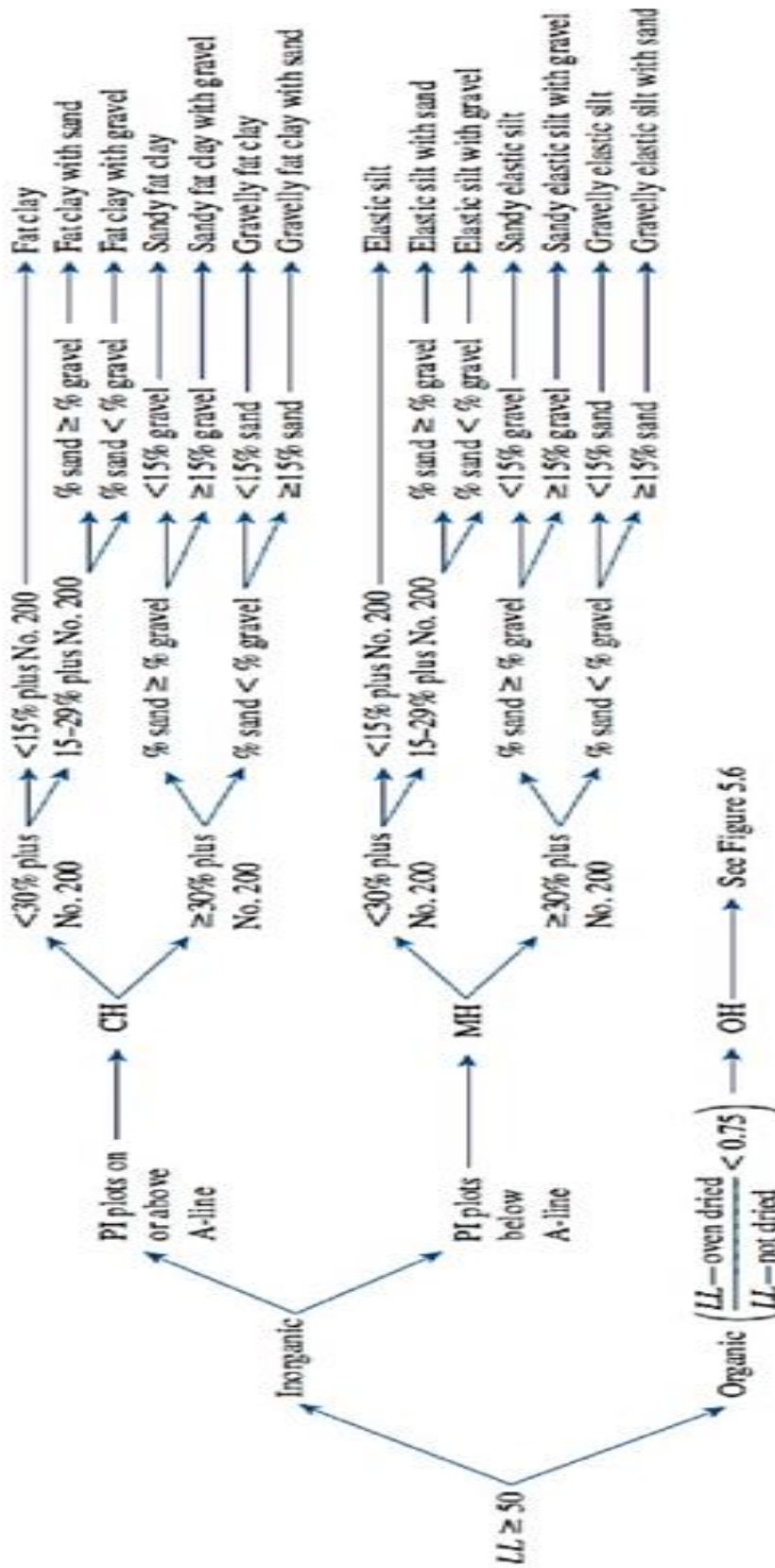

Flowchart group names for inorganic silty and clayey silt (Source: [http://www.astm.org](#) "Annual Book of ASTM Standards, 04.06." Copyright ASTM

INTERNATIONAL. Reprinted with permission.)

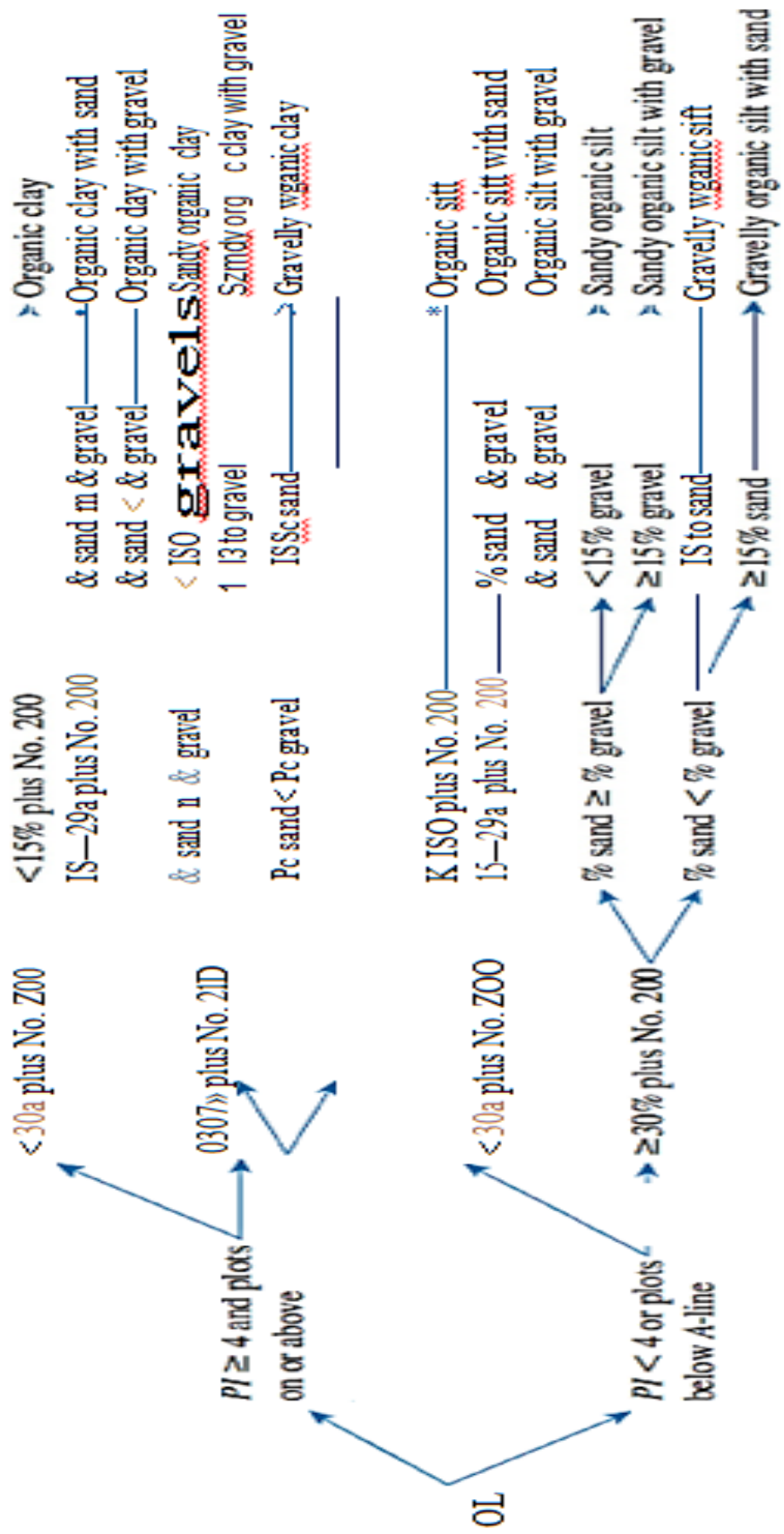

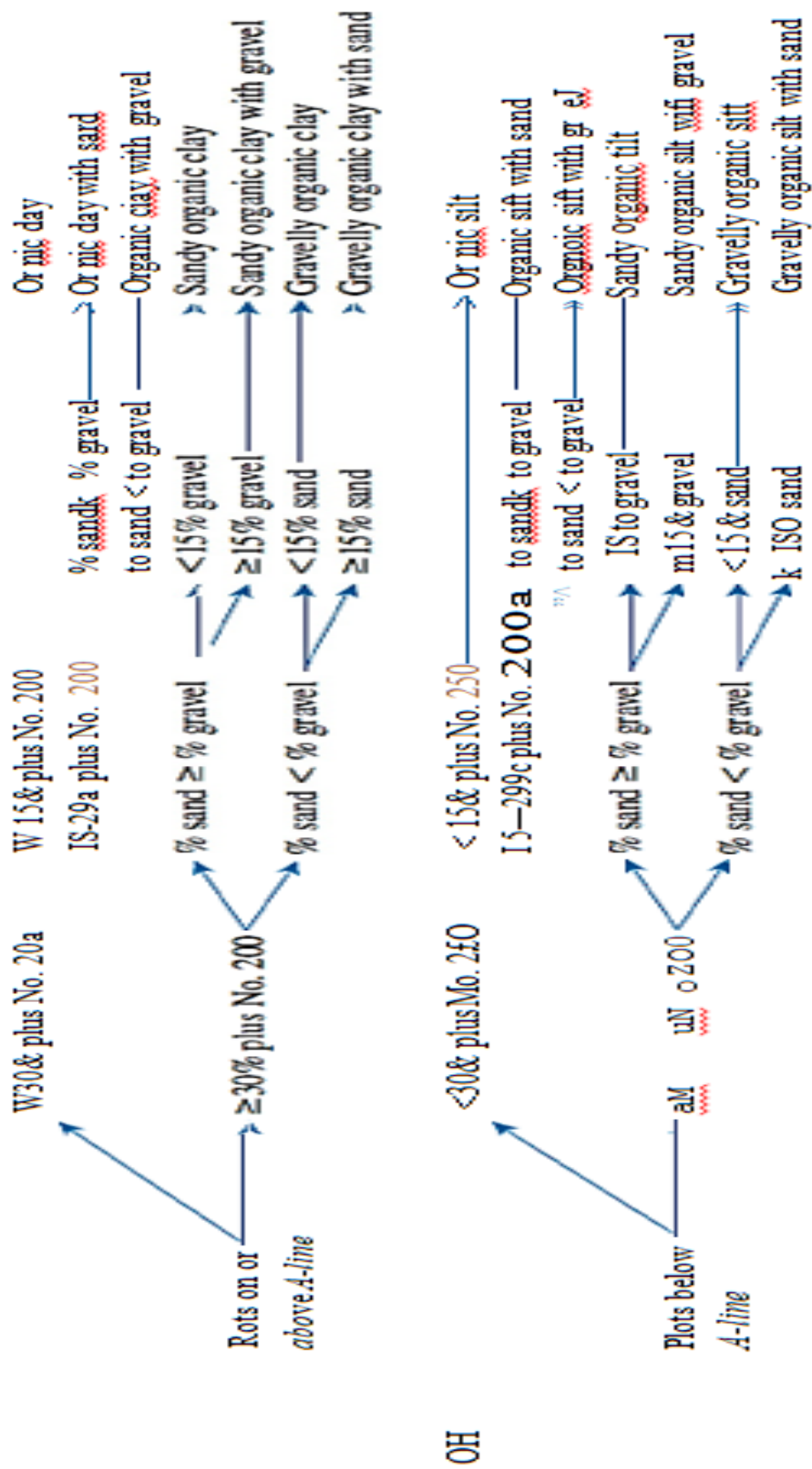

**Flowchart group names for organic silty and clayey soils {Source. From “Annual Book of ASTM Standards, 04.08.” Copyright ASTM INTERNATIONAL. Reprinted with permission.)**

**Example (3.13)**

The results of the particle-size analysis of soil are as follows: Percent passing through the No. 10 sieve = 100  
Percent passing through the No. 40 sieve = 80  
Percent passing through the No. 200 sieve = 58

The liquid limit and plasticity index of the minus No. 40 fraction of the soil are 30 and 10, respectively. Classify the soil by the Unified classification system.

**Solution**

Since 58% of the soil passes through the No. 200 sieve, it is a fine-grained soil. Referring to the plasticity chart, for  $LL = 30$  and  $PI = 10$ , it can be classified (group symbol) as CL.

To determine the group name. The percent passing No. 200 sieve is more than 30%. Percent of gravel = 0; percent of sand =  $(100 - 58) - (0) = 42$ . Hence, percent sand  $>$  percent gravel. Also, percent gravel is less than 15%. Hence the group name is **sandy lean clay**.

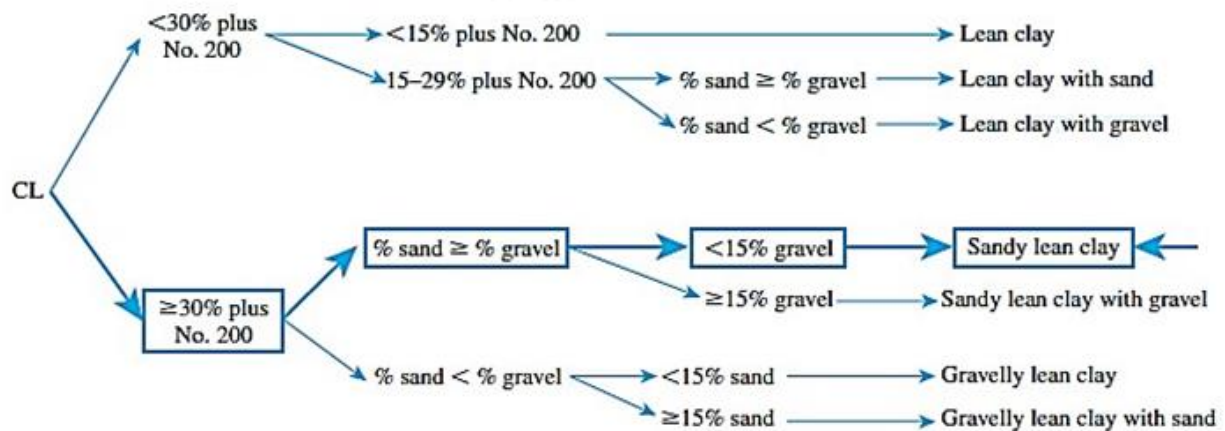

### **Example (3.14)**

For a given soil, the following are known:

- Percentage passing through No. 4 sieve = 70
- Percentage passing through No. 200 sieve = 30
- Liquid limit = 33
- Plastic limit = 12

Classify the soil using the Unified Soil Classification System. Give the group symbol and the group name.

### **Solution**

The percentage passing No. 200 sieve is 30%, which is less than 50%. So it is a coarse-grained soil. Thus

$$\text{Coarse fraction} = 100 - 30 = 70\%$$

$$\text{Gravel fraction} = \text{percent retained on No. 4 sieve} = 100 - 70 = 30\%$$

Hence, more than 50% of the coarse fraction is passing No. 4 sieve. Thus, it is a sandy soil. Since more than 12% is passing No. 200 sieve, it is SM or SC. For this soil,

$PI = 33 - 12 = 21$  (which is greater than 7). With  $LL = 33$  and  $PI = 21$ , it plots above the A-line. Thus the group symbol is SC.

Since the percentage of gravel is more than 15%, it is **clayey sand with gravel**.



**CHAPTER FOUR**  
***STRESSES IN SOIL***

## **4.1 Introduction**

The soils are multiphase systems. In a given volume of soil, the solid particles are distributed randomly with void spaces between. The void spaces are continuous and are occupied by water and/or air. To analyze problems (such as compressibility of soils, bearing capacity of foundations, the stability of embankments, and lateral pressure on earth-retaining structures), It needs to know the nature of the distribution of stress in a given cross section of the soil profile.

In an original soil, it obviously is impossible to keep track of forces at each contact point. Also, it is necessary to use the concept of stress.

Stresses within the soil are:

1- **Geostatic stress**: Sub Surface Stresses caused by mass of soil

- A. Vertical stress
- B. Horizontal Stress

2- **Stresses due to surface loading**:

- A. infinitely loaded area (filling)
- B. Point load (concentrated load)
- C. Circular loaded area.
- D. Rectangular loaded area.

## **4.2 Geostatic Stresses**

When the ground surface is horizontal, and when the nature of the soil varies but little in the horizontal direction. In such a situation, the stresses are called *Geostatic Stresses*

### **4.2.1 Vertical Geostatic Stresses**

The vertical geostatic stresses at any depth can be computed by considering the weight of soil above the depth. If the unit weight of the soil is constant



with depth:

$$\sigma_v = \gamma z$$

where

$z$ : is the depth of the point considered and  $\gamma$  is the soil unit weight For layered soil:

$$\sigma_v = \gamma_1 z_1 + \gamma_2 z_2 + \gamma_3 z_3$$

$$\sigma_v = \sum \gamma_i z_i$$

If the unit weight is varied with depth

$$\sigma_v = \int_0^z \gamma_i dz$$

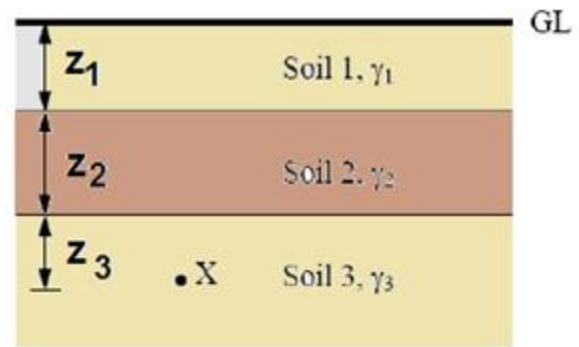
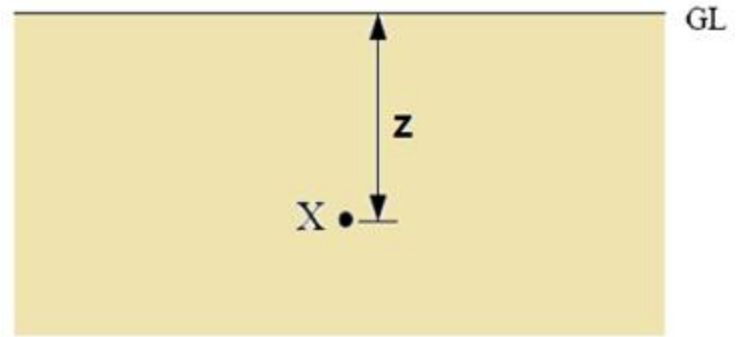

### Example (4.1)

For the soil profile, calculate the vertical stresses at points (A), (B), and (C).

### Solution

For point (A),  $z =$

0, thus  $\sigma_v = 0$

For point (B)

$$\sigma_v = \gamma z =$$

$$16.5 * 6 = 99 \text{ kN/m}^2$$

For point (C)

$$\sigma_v = \sum \gamma_i z_i = 16.5 * 6 + 17.8 * 13 = 330.4 \text{ kN/m}^2$$

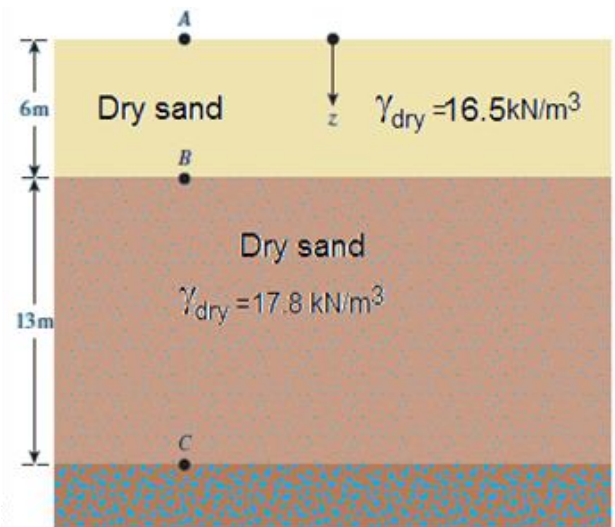

## 4.2.2 Effective Vertical Stresses

In saturated soils, the normal stress ( $\sigma_v$ ) at any point within the soil mass is shared by the soil grains and the water held within the pores. The component of the normal stress acting on the soil grains, is called effective stress or inter granular stress, and is generally denoted by  $\sigma'$ . The remainder, the normal stress acting on the pore water, is known as pore water pressure or neutral stress and is denoted by ( $u$ ). Thus, the total stress at any point within the soil mass can be written as:

$$\sigma = \sigma' + u$$

This applies to normal stresses in all directions at any point within the soil mass. In dry soil, there is no pore water pressure and the total stress is the same as effective stress.

In geostatic stresses there is no shear stress in soil, also water cannot carry any shear stress.

### Example (4.2)

For the soil profile calculate the vertical total, effective stresses and pore water pressure at points (A), (B), and (C).

#### Solution

At Point A:

$$\text{Total stress: } \sigma_{vA} = 0$$

$$u_A = 0 = \sigma'_{vA} = 0$$

At Point B

$$\sigma_{vB} = \gamma z = 16.5 * 6 = 99 \text{ kN/m}^2$$

$$u_B = 0$$

$$\sigma'_{vB} = 99 - 0 = 99 \text{ kN/m}^2$$

At Point C

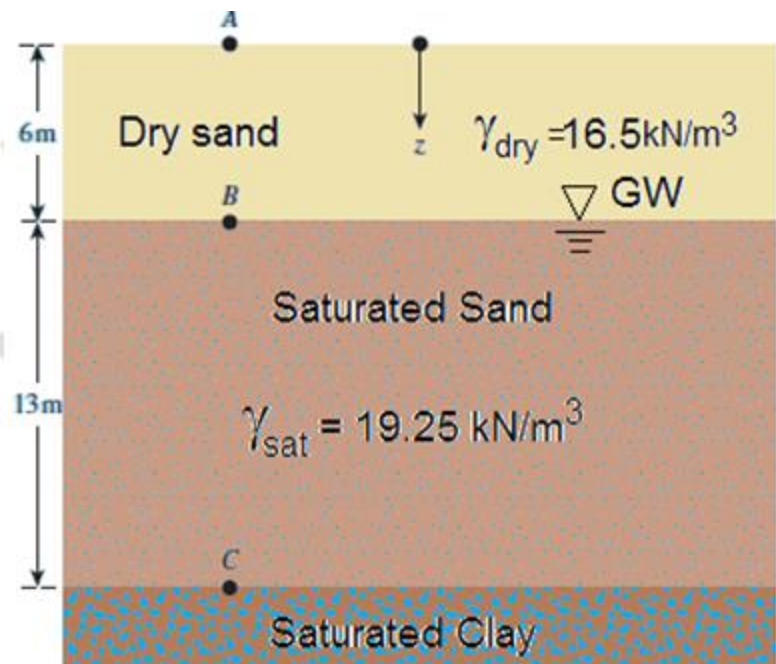

$$\sigma_{vC} = \sum \gamma_i z_i = 16.5 * 6 + 19.25 * 13 = 349.25 \text{ kN/m}^2 ,$$

$$u_C = 13 * 9.81 = 127.53 \text{ kN/m}^2$$

$$\sigma'_{vC} = 349.25 - 127.53 = 221.72 \text{ kN/m}^2$$

### Example (4.3)

Plot the variation of total and effective vertical stresses, and pore water pressure with depth for the soil profile shown below:

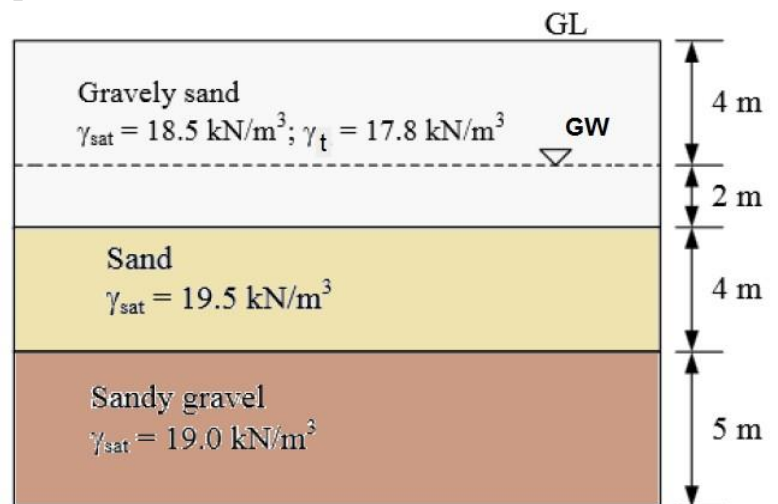

### Solution

Within a soil layer, the unit weight is constant, and therefore the stresses vary linearly. Therefore, it is adequate if we compute the values at the layer interfaces and water table location, and join them by straight lines. At the ground level,

At depth = 0

$\sigma_v = 0$  ;  $\sigma'_v = 0$ ; and  $u = 0$

At 4 m depth,

$\sigma_v = (4)(17.8) = 71.2$  kPa;  $u = 0$

$\therefore \sigma'_v = 71.2$  kPa

At 6 m depth,  $\sigma_v = (4)(17.8) + (2)(18.5) = 108.2$  kPa

$u = (2)(9.81) = 19.6$  kPa

$\therefore \sigma'_v = 108.2 - 19.6 = 88.6$  kPa

At 10 m depth,

$\sigma_v = (4)(17.8) + (2)(18.5) + (4)(19.5) = 186.2$  kPa

$u = (6)(9.81) = 58.9$  kPa

$\therefore \sigma'_v = 186.2 - 58.9 = 127.3$  kPa

At 15 m depth,

$\sigma_v = (4)(17.8) + (2)(18.5) + (4)(19.5) + (5)(19.0) = 281.2$  kPa

$u = (11)(9.81) = 107.9$  kPa

$\therefore \sigma'_v = 281.2 - 107.9 = 173.3$  kPa

The values of  $\sigma$ ,  $u$ , and  $\sigma'$  computed above are summarized in Table

Depth (m)	$\sigma_v$ (kPa)	U (kPa)	$\sigma'_v$ (kPa)
0	0	0	0
4	71.2	0	71.2
6	108.2	19.6	88.6
10	186.2	58.9	127.3
15	281.2	107.9	173.3

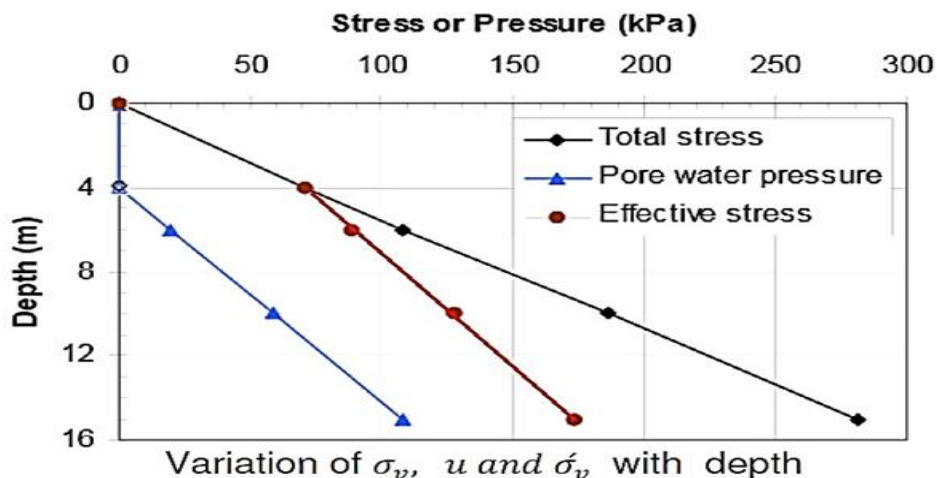

### Example (4.4)

Refer to Example 4.2. How high should the water table rise so that the effective stress at C is 190 kN/m<sup>2</sup>? Assume  $\gamma_{\text{sat}}$  to be the same for both layers (i.e., 19.25 kN/m<sup>3</sup>).

#### Solution:

Let the groundwater table rise be (h) above the present groundwater table

$$\sigma_c = (6 - h)\gamma_{\text{dry}} + h\gamma_{\text{sat}} + 13\gamma_{\text{sat}}$$

$$u = (h + 13)\gamma_w$$

So

$$\begin{aligned}\sigma'_c &= \sigma_c - u = (6 - h)\gamma_{\text{dry}} + h\gamma_{\text{sat}} + 13\gamma_{\text{sat}} - h\gamma_w - 13\gamma_w \\ &= (6 - h)\gamma_{\text{dry}} + h(\gamma_{\text{sat}} - \gamma_w) + 13(\gamma_{\text{sat}} - \gamma_w)\end{aligned}$$

$$190 = (6 - h)16.5 + h(19.25 - 9.81) + 13(19.25 - 9.81)$$

$$h = 4.49 \text{ m}$$

### 4.2.3 Horizontal Effective stresses

The horizontal geostatic stress can be computed as following:

$$\sigma'_h = k_o \sigma'_v$$

$k_o$  is the coefficient of lateral stress

In sand soil and normally consolidated clay  $k_o < 1.0 = 1 - \sin\phi$ ,

where  $\phi$  is the angle of internal friction of soil

In over consolidated clay  $k > 1.0$

The stress to which soil has been subjected during its formation to the present time referred as stress history. During deposition, effective stress increased as more soil particle are placed, and during effective erosion, stress decreased as the soil particles are removed. Due to this, there are two types of soils:

Normally consolidated clay and sand:

This soil has undergone deposition only if the water table is assumed at the ground level, the vertical and horizontal effective stresses are increased, and the void ratio of the soil reduced the plot of void ratio versus effective stress

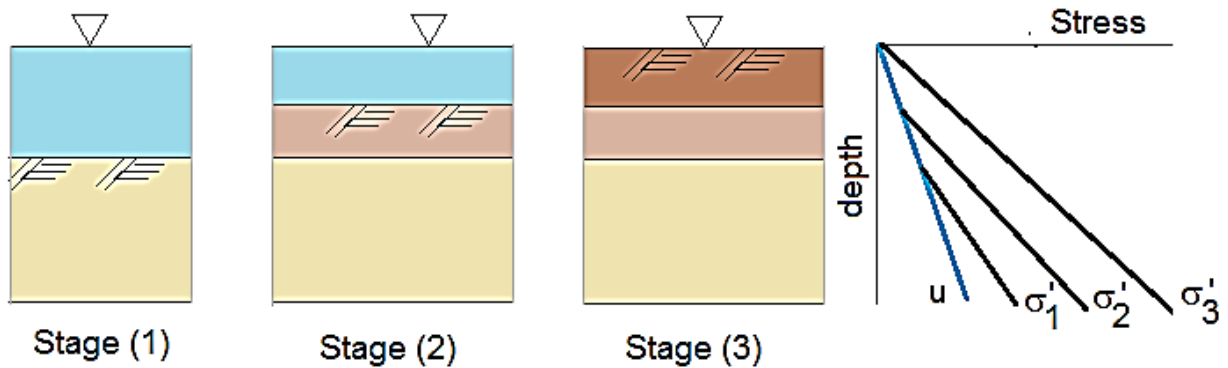

on the semi-log scale is usually a straight line. During deposition the mineral grains of the soil elements will be rearranged and become closer, the effective stress at the stage will be maximum ( $p'_o$ ).

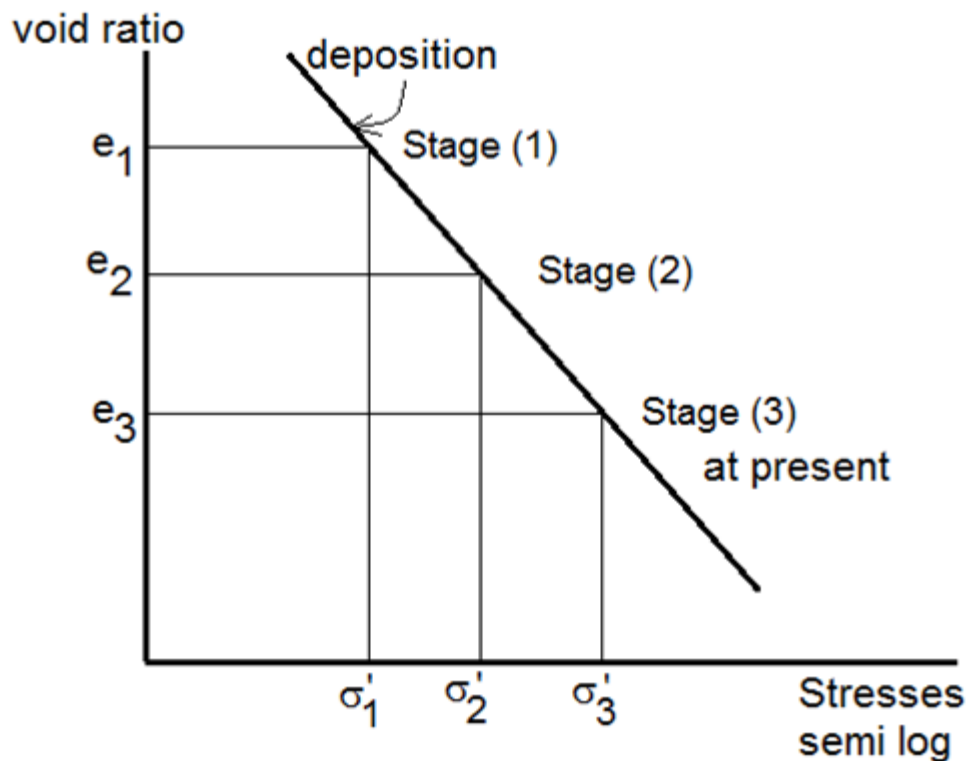

### Overconsolidated Clay:

In this case, the soil has been subjected to effective stress in its past stress history.  $(p'_c)$  is larger than the effective stress at present  $(p'_o)$

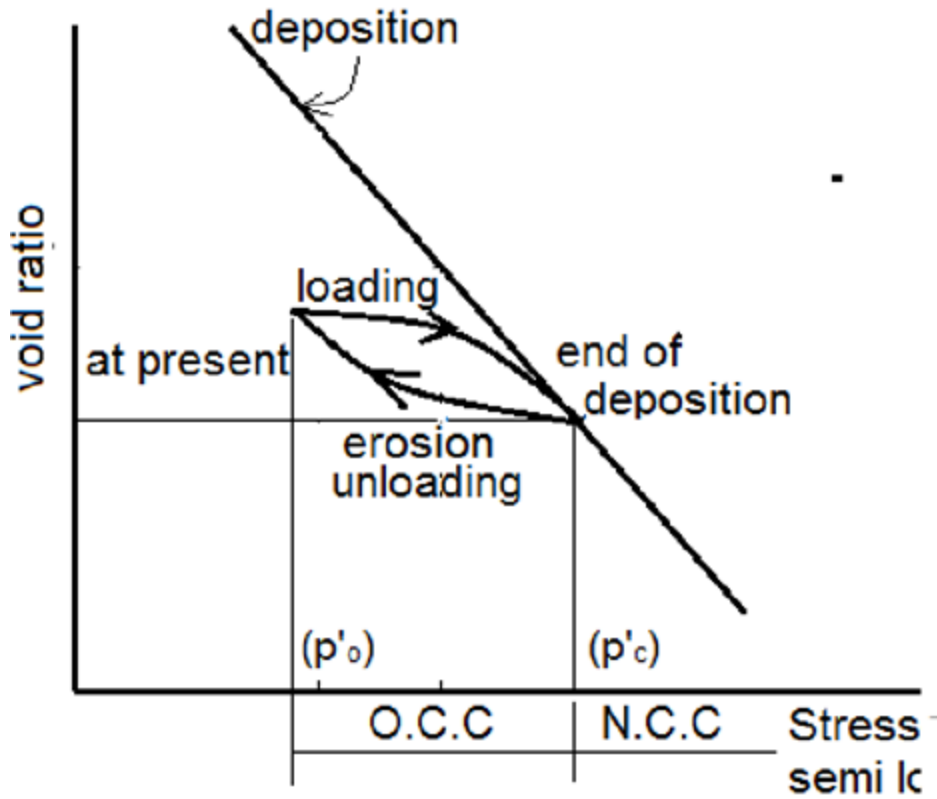

When the soil is reloaded from  $(p'_o)$ , it reached  $(p'_c)$ .

At this stage the soil is over-consolidated. The over-consolidated ratio (O.C.R) =  $p'_c / p'_o$

- Normally consolidated clay (O.C.R) = 1.0
- Lightly over-consolidated clay (O.C.R) = 1.5 - 3
- over-consolidated clay (O.C.R) = > 4

### Example (4.5)

Compute the vertical and horizontal total and effective stresses and pore water pressure at element (A)

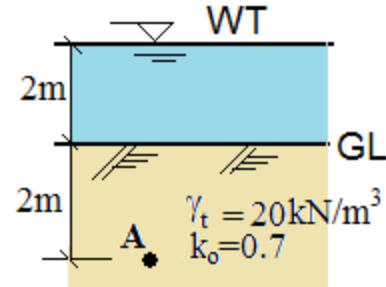

### Solution:

In this example, the water above soil is an additional load on the soil thus:

$$\text{Total vertical stress at A, } \sigma_v = 9.81 * 2 + 20 * 2 = 59.62 \text{ kN/m}^2$$

$$\text{Pore water pressure at A } u = 9.81 * 4 = 39.24 \text{ kN/m}^2$$

$$\text{Effective vertical stress at A } \sigma'_v = 59.62 - 39.24 = 20.38 \text{ kN/m}^2$$

$$\text{Effective horizontal stress at A, } \sigma'_h = K \sigma'_v = 0.7 * 20.8 = 14.266 \text{ kN/m}^2$$

$$\text{Total horizontal stress at A, } \sigma_h = \sigma'_h + u = 14.266 + 39.24 = 53.51 \text{ kN/m}^2$$

### Example (4.6)

Compute the vertical and horizontal total and effective stresses and pore water pressure at element (1), (2), and (3).

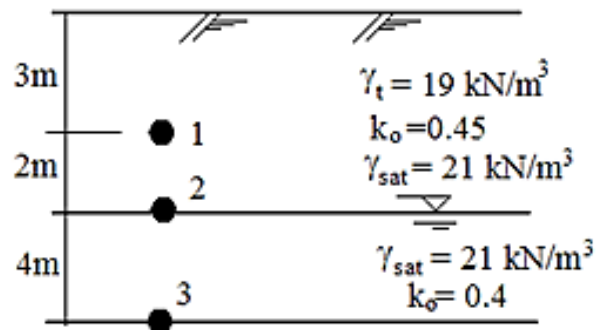

### Solution:

Point (1)

$$\text{Total vertical stress at point (1), } \sigma_v = 19 * 3 = 57 \text{ kN/m}^2$$

$$\text{Pore water pressure at (1), } u = 9.81 * 0 = 0 \text{ kN/m}^2$$

$$\text{Effective vertical stress at (1), } \sigma'_v = 57 - 0 = 57 \text{ kN/m}^2$$



Effective horizontal stress at (1),  $\sigma'_h = k_o * \sigma'_v = 0.45 * 57 = 25.65 \text{ kN/m}^2$

Total horizontal stress at (1),  $\sigma_h = \sigma'_h + u = 25.65 + 0 = 25.65 \text{ kN/m}^2$

Point (2)

Total vertical stress at point (2),  $\sigma_v = 19 * (3+2) = 95 \text{ kN/m}^2$

Pore water pressure at (2),  $u = 9.81 * 0 = 0 \text{ kN/m}^2$

Effective vertical stress at (2),  $\sigma'_v = 95 - 0 = 95 \text{ kN/m}^2$

Effective horizontal stress at (2),  $\sigma'_h = k_o * \sigma'_v = 0.45 * 95 = 42.72 \text{ kN/m}^2$

Total horizontal stress at (2),  $\sigma_h = \sigma'_h + u = 42.72 + 0 = 42.72 \text{ kN/m}^2$

Point (3)

Total vertical stress at point (3),  $\sigma_v = 95 + 21 * 4 = 179 \text{ kN/m}^2$

Pore water pressure at (3),  $u = 9.81 * 4 = 39.24 \text{ kN/m}^2$

Effective vertical stress at (3),  $\sigma'_v = 179 - 39.24 = 139.76 \text{ kN/m}^2$

Effective horizontal stress at (3),  $\sigma'_h = k_o * \sigma'_v = 0.40 * 139.76 = 55.9 \text{ kN/m}^2$

Total horizontal stress at (3),  $\sigma_h = \sigma'_h + u = 55.9 + 39.24 = 95.14 \text{ kN/m}^2$

### 4.3 Normal and Shear Stresses on a Plane

This section is a brief review of the basic concepts of normal and shear stresses on a plane that can be found in any course on the mechanics of materials.

The Figure shows a two-dimensional soil element that is being subjected to normal and shear stresses ( $\sigma_y > \sigma_x$ ). To determine the normal stress and the shear stress on a plane EF that makes an angle  $\theta$  with the plane AB, the free body diagram of EFB shown. Let  $\sigma_n$  and  $\tau_n$  be the normal stress and the shear stress respectively, on the plane EF. From geometry.

$$\overline{EB} = \overline{EF} \cos \theta \quad \text{and} \quad \overline{FB} = \overline{EF} \sin \theta$$

Summing the components of forces that act on the element in the direction of N and T,

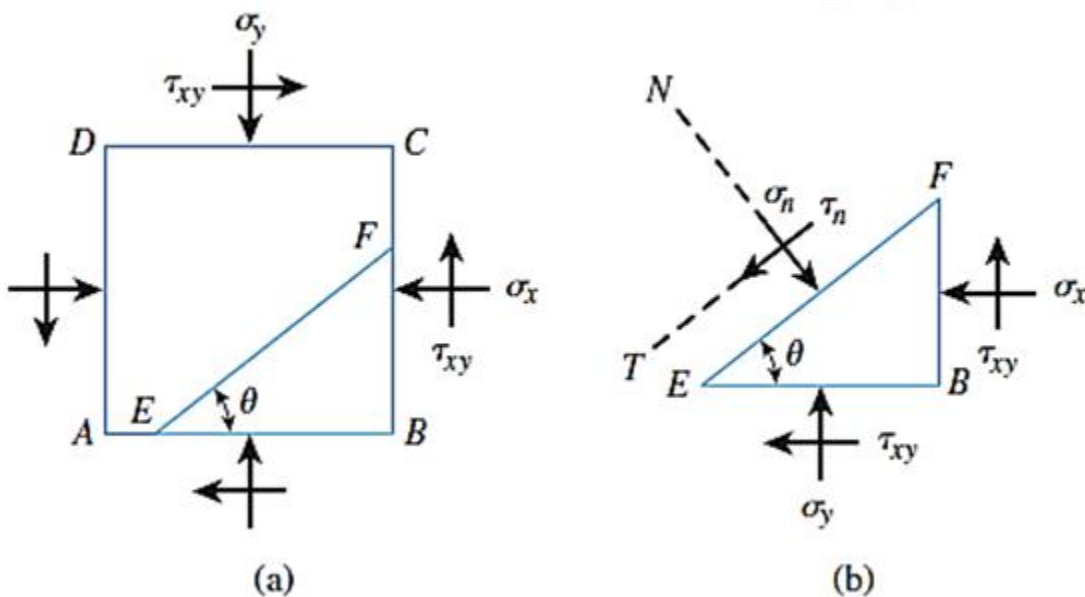

$$\sigma_n(\overline{EF}) = \sigma_x(\overline{EF}) \sin^2 \theta + \sigma_y(\overline{EF}) \cos^2 \theta + 2\tau_{xy}(\overline{EF}) \sin \theta \cos \theta$$

$$\text{or } \sigma_n = \sigma_x \sin^2 \theta + \sigma_y \cos^2 \theta + 2\tau_{xy} \sin \theta \cos \theta$$

or

$$\sigma_n = \frac{\sigma_y + \sigma_x}{2} + \frac{\sigma_y - \sigma_x}{2} \cos 2\theta + \tau_{xy} \sin 2\theta$$

Again,

$$\tau_n(\overline{EF}) = -\sigma_x(\overline{EF}) \sin \theta \cos \theta + \sigma_y(\overline{EF}) \sin \theta \cos \theta - \tau_{xy}(\overline{EF}) \cos^2 \theta + \tau_{xy}(\overline{EF}) \sin^2 \theta$$

$$\text{or } \tau_n = \sigma_y \sin \theta \cos \theta - \sigma_x \sin \theta \cos \theta - \tau_{xy}(\cos^2 \theta - \sin^2 \theta)$$

$$\tau_n = \frac{\sigma_y - \sigma_x}{2} \sin 2\theta - \tau_{xy} \cos 2\theta$$

If  $\tau_n$  equal to zero:

$$\tan 2\theta = \frac{2\tau_{xy}}{\sigma_y - \sigma_x}$$

For given values of  $\tau_{xy}$ ,  $\sigma_y$  and  $\sigma_x$  will give two values of  $\theta$  that are  $90^\circ$  apart. This means, that there are two planes that are at right angles to each other on which the shear stress is zero. Such planes are called **Principal Planes**. The normal stresses that act on the principal planes are referred to as **Principal Stresses**.

Principal stresses: the normal stresses acting on principal planes, the largest principal stress is called **Major Principal Stress** ( $\sigma_1$ ), and the smallest principal stress is called **Minor Principal Stress** ( $\sigma_3$ ). The third is called the intermediate principal stress ( $\sigma_2$ )

In isotropic soils  $\sigma_3 = \sigma_2$

In anisotropic soil  $\sigma_3 \neq \sigma_2$

**Isotropic soil:** soils that have similar properties at a given location at all planes of all directions

**Principal Planes:** three planes which is normally stresses act on it and *No Shear Stress*

In Geostatic Condition:

$k < 1.0$ ,  $\sigma_v = \sigma_1$ ,  $\sigma_h = \sigma_3$

$k > 1.0$ ,  $\sigma_v = \sigma_3$ ,  $\sigma_h = \sigma_1$

$k < 1.0$ ,  $\sigma_v = \sigma_h = \sigma_1 = \sigma_3$

The normal stress and shear stress that act on any plane can also be determined by plotting a Mohr's circle, as shown in Figure. The following sign conventions are used in Mohr's circles:

Compressive normal stresses are taken as positive.

Shear stresses are considered positive if they act on opposite faces of the element in such a way that they tend to produce a counterclockwise rotation. The angle  $\theta$  is positive when measured counterclockwise from major principal plane.

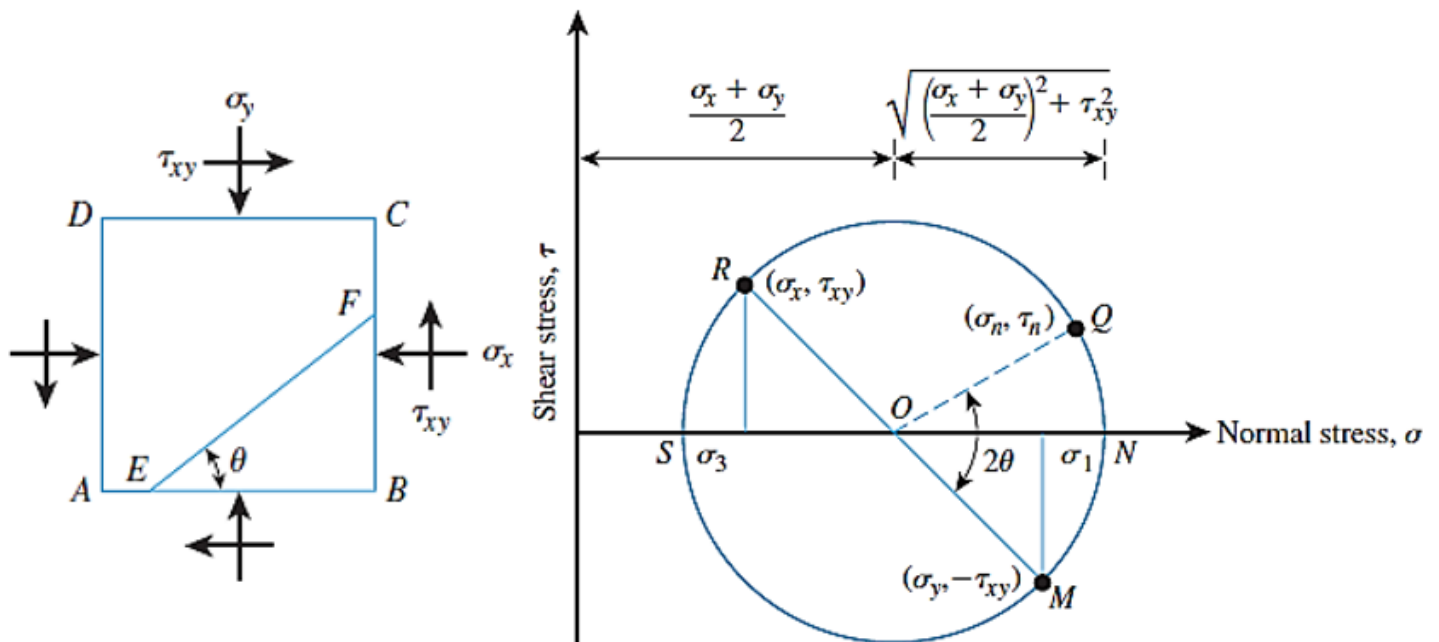

For plane AD of the soil element shown in Figure, normal stress equals  $+\sigma_x$  and shear stress equals  $+\tau_{xy}$ . For plane AB, normal stress equals  $+\sigma_y$  and shear stress equals  $-\tau_{xy}$ .

The points R and M in Figure represent the stress conditions on planes AD and AB, respectively. O is the point of intersection of the normal stress axis with the line RM. The circle MNQRS drawn with q as the center and OR as the radius is the Mohr's circle for the stress conditions considered. The radius of the Mohr's circle is equal to:

$$\sqrt{\left[\frac{(\sigma_y - \sigma_x)}{2}\right]^2 + \tau_{xy}^2}$$

The stress on plane EF can be determined by moving an angle  $2\theta$  (which is twice the angle that the plane EF makes in a counterclockwise direction with plane AB in a counterclockwise direction from point M along the circumference of the Mohr's circle to reach point Q. The abscissa and ordinate of point Q, respectively, give the normal stress  $\sigma_n$  and the shear stress  $+\tau_n$  on plane EF. The abscissa of point N is equal to  $\sigma_1$ , and the abscissa for point S is  $\sigma_3$ .

As a special case, if the planes AB and AD were major and minor principal planes, the normal stress and the shear stress on plane EF could be found by substituting  $\tau_{xy} = 0$ .

If  $\sigma_y = \sigma_1$  and  $\sigma_x = \sigma_3$  Thus,

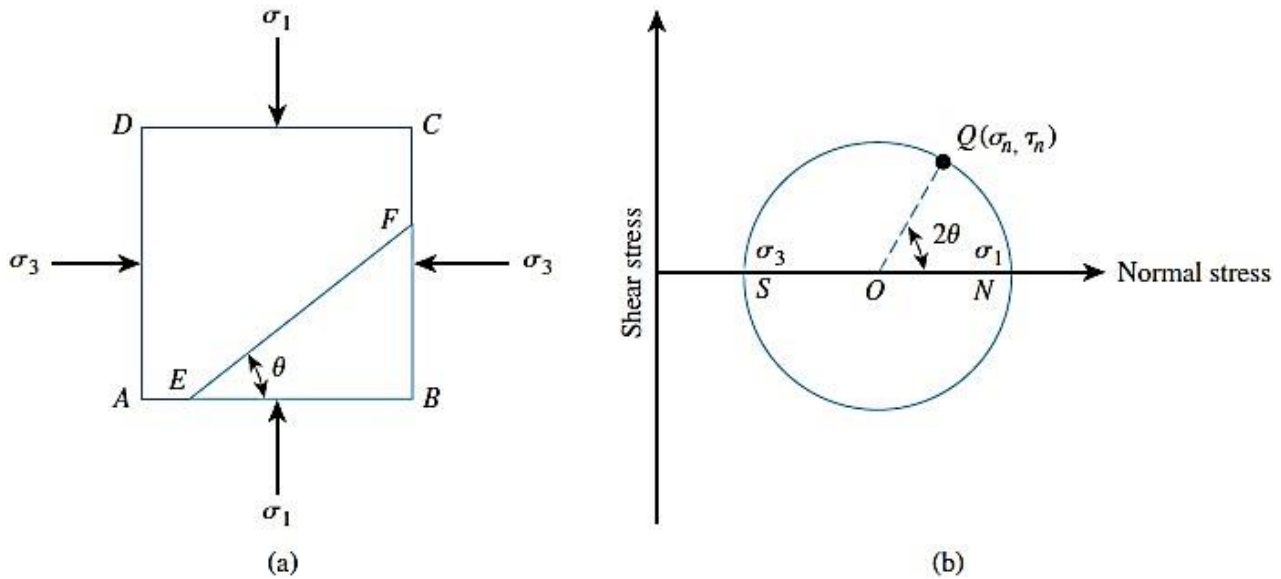

**Example 4.9**

The magnitudes of stresses are  $\sigma_1 = 120 \text{ kN/m}^2$ ,  $\tau_{xy} = 40 \text{ kN/m}^2$ ,  $\sigma_y = 300 \text{ kN/m}^2$ , and  $\theta = 20^\circ$ . Determine

- a. Magnitudes of the principal stresses.
- b. Normal and shear stresses on plane AB.

**Solution**

$$\begin{aligned}
 \left. \begin{matrix} \sigma_3 \\ \sigma_1 \end{matrix} \right\} &= \frac{\sigma_y + \sigma_x}{2} \pm \sqrt{\left[ \frac{\sigma_y - \sigma_x}{2} \right]^2 + \tau_{xy}^2} \\
 &= \frac{300 + 120}{2} \pm \sqrt{\left[ \frac{300 - 120}{2} \right]^2 + (-40)^2}
 \end{aligned}$$

$$\sigma_1 = 308.5 \text{ kN/m}^2$$

$$\sigma_3 = 111.5 \text{ kN/m}^2$$

(b)

$$\begin{aligned}
 \sigma_n &= \frac{\sigma_y + \sigma_x}{2} + \frac{\sigma_y - \sigma_x}{2} \cos 2\theta + \tau \sin 2\theta \\
 &= \frac{300 + 120}{2} + \frac{300 - 120}{2} \cos (2 \times 20) + (-40) \sin (2 \times 20) \\
 &= 253.23 \text{ kN/m}^2
 \end{aligned}$$

$$\begin{aligned}\tau_n &= \frac{\sigma_y - \sigma_x}{2} \sin 2\theta - \tau \cos 2\theta \\ &= \frac{300 - 120}{2} \sin (2 \times 20) - (-40) \cos (2 \times 20) \\ &= 88.40 \text{ kN/m}^2\end{aligned}$$

### The Pole Method of Finding Stresses along a Plane

Another important technique of finding stresses along a plane from a Mohr's circle is the pole method, or the method of origin of planes. This is demonstrated in Figure.

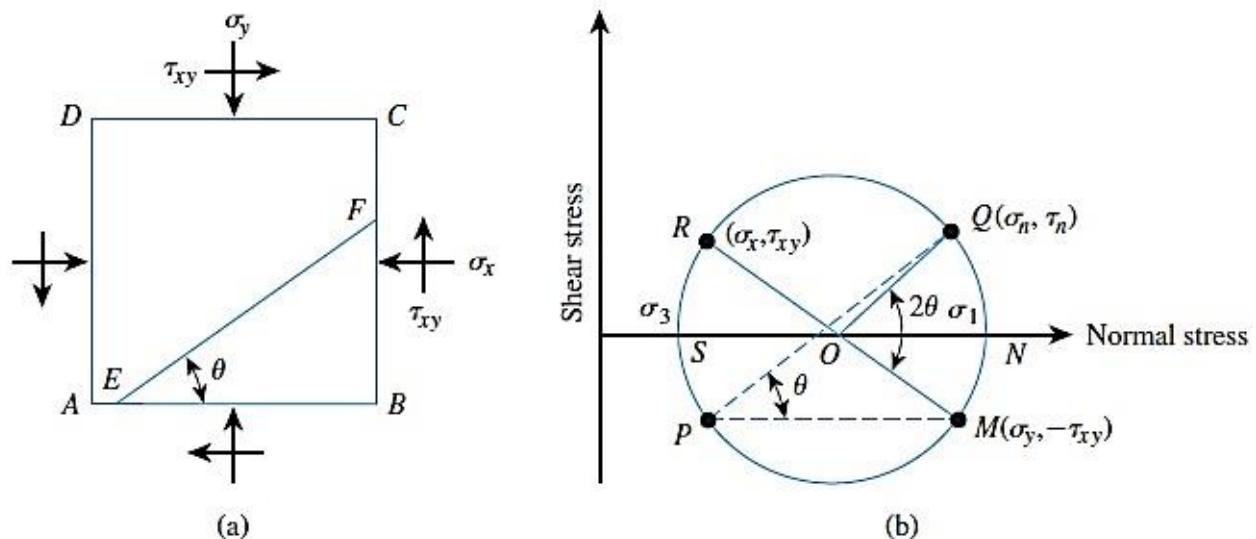

In this method draw a line from a known point on the Mohr's circle parallel to the plane on which the state of stress acts. The point of intersection of this line with the Mohr's circle is called the pole. This is a unique point for the state of stress under consideration.

For example, the point M on the Mohr's circle in Figure represents the stresses on the plane AB. The line MP is drawn parallel to AB. Therefore,

point P is the pole (origin of planes) in this case. To find the stresses on a plane EF, draw a line from the pole parallel to EF. The point of intersection of this line with the Mohr's circle is Q. The coordinates of Q give the stresses on the plane EF. (Note: From geometry, angle QOM is twice the angle QPM.)

### Example(4.10)

For a given in figure find the stresses at plane

**B-B Case one: Given  $\sigma_1$  and  $\sigma_3$ , required**

$\sigma_\theta$  and  $\tau_\theta$

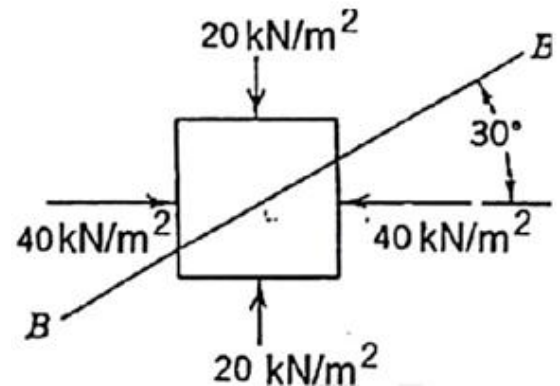

### Solution

1. locate points with co-ordinates (40,0) and (20,0)
2. Draw circle, using these points to defined diameter, diameter location =  $(40+20)/2 = 30 \text{ kN/m}^2$ , thus center location is (30, 0).
3. Draw line A' A' through point (20, 0) and parallel to plane on which stress (20, 0) acts.
4. Intersection of line A' A' with Mohr's circle at point (40,0) is origin of planes
5. Draw line B'B' through point OP parallel to BB
6. Read coordinates of point X where B'B' intersect Mohr circle

$$\sigma_\theta = 25 \text{ kN/m}^2, \tau_\theta = - 8.7 \text{ kN/m}^2$$



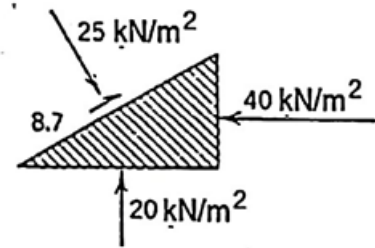
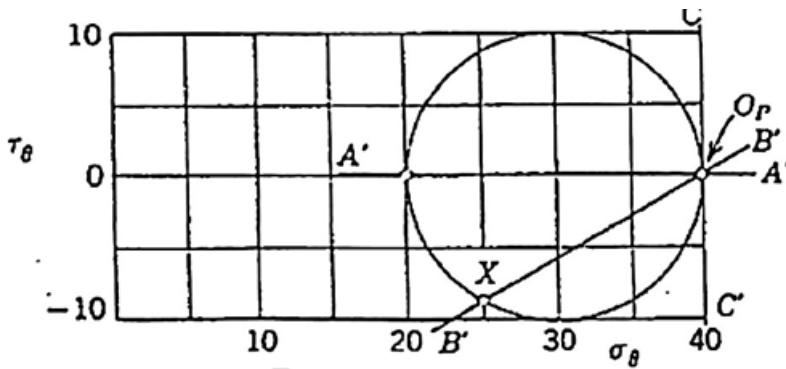

Alternate Solution, Step 1 and Step 2 same as above

3. Draw line C'C' through (40, 0) parallel to plane on which stress (40, 0) acts. C'C' is vertical
4. C'C' intersects Mohr circle only at (40,0), so this is  $O_P$ , Step 5 and 6 same as above

By using equations

$$\sigma_{\theta} = \frac{\sigma_1 + \sigma_3}{2} + \frac{\sigma_1 - \sigma_3}{2} \cos 2\theta$$

$$\sigma_{\theta} = \frac{40 + 20}{2} + \frac{40 - 20}{2} \cos(2 * 120) = 30 + (-5) = 25$$

$$\tau = \frac{(\sigma_1 - \sigma_3)}{2} \sin 2\theta$$

$$\tau = \frac{(40 - 20)}{2} \sin(2 * 120) = -8.66 \text{ kN/m}^2$$

### Example (4.11)

For a given in figure find the stresses at plane D-D

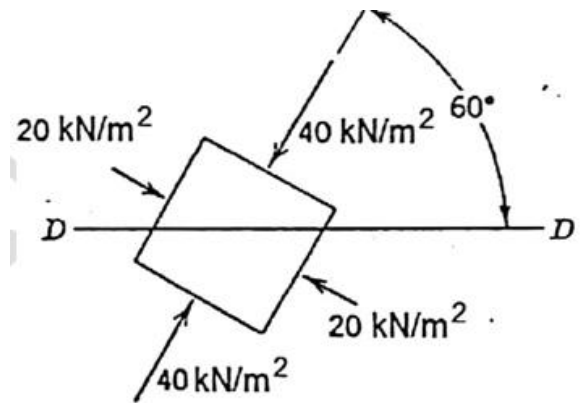

### Solution

1. locate points with co-ordinates (40,0) and (20,0)
2. Draw Mohr circle, using these points to defined diameter, diameter location =  
 $(40+20)/2 = 30 \text{ kN/m}^2$ , thus center location is (30, 0).
3. Draw line A' A' through point (20, 0) and parallel to plane on which stress (20, 0) acts.
4. Intersection of line A' A' with Mohr's circle gives origin of planes
5. Draw line D'D' through point o OP parallel to DD
6. Intersection X give stresses

$$\sigma_x = 35 \text{ kN/m}^2, \tau_{xy} = 8.7 \text{ kN/m}^2$$

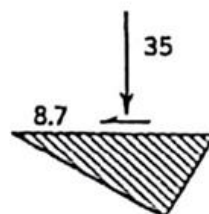
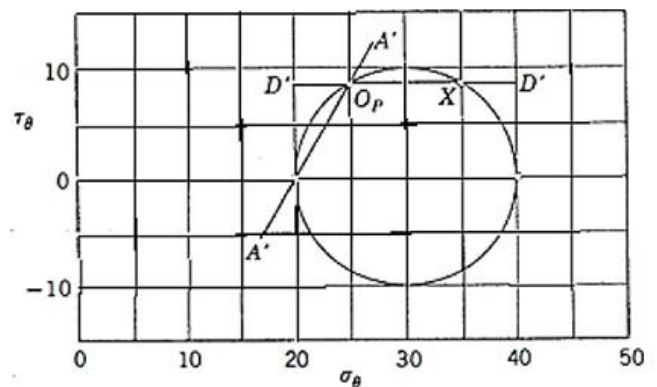

### Example (4.12)

For a given in figure find the direction and magnitude of principal stresses

**Case two: Given  $\sigma_\theta$  and  $\tau_\theta$ , required  $\sigma_1$**

and  $\sigma_3$

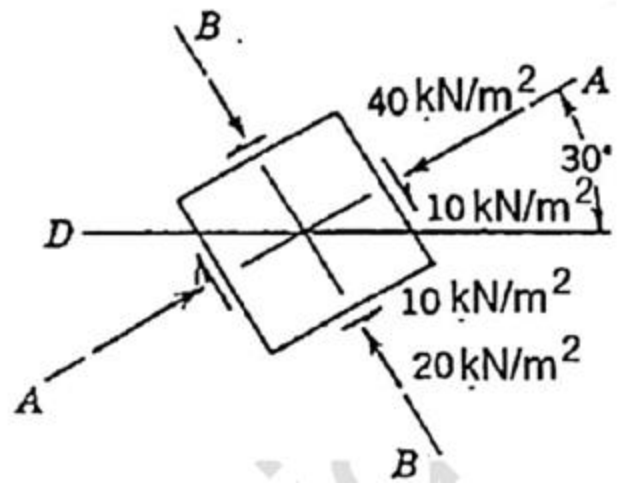

### Solution

1. locate points (40,-10) and (20,10)
2. Erect diameter and draw Mohr circle, using these points to defined diameter, diameter location =  $(40+20)/2 = 30 \text{ kN/m}^2$ , thus center location is (30, 0).
3. Draw line B' B' through point (40, -10) and parallel BB.
4. Read  $s_1$  and  $s_3$  from graph
5. Line though OP and  $\sigma_1$  give plane on which  $\sigma_1$  acts.

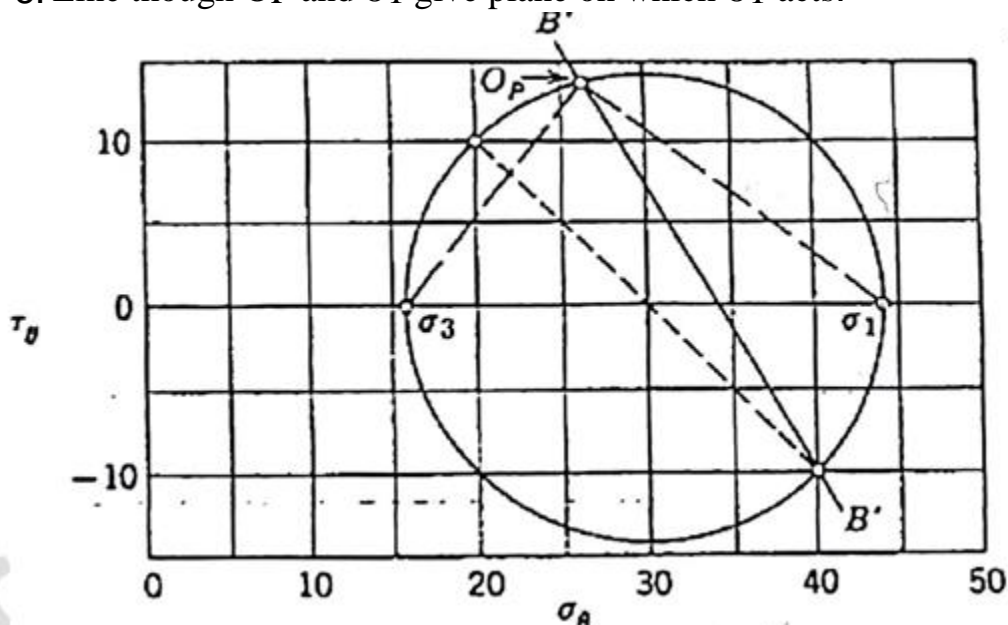

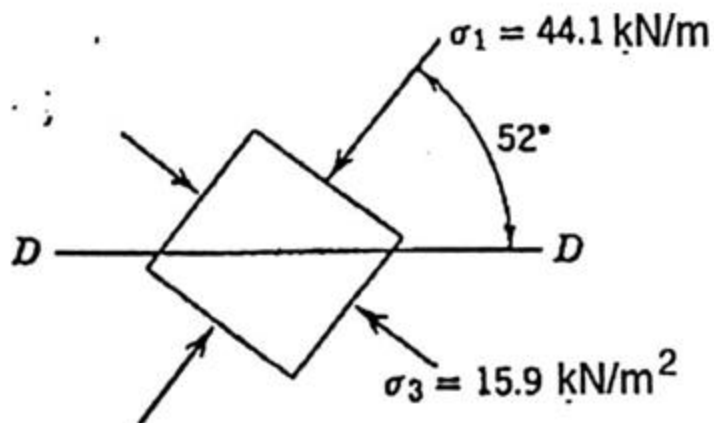

Solution by equations

1. First make use of fact that sum of normal stresses is a constant:

$$\frac{\sigma_1 + \sigma_3}{2} = \frac{\Sigma \sigma_{\theta}}{2} = \frac{40 + 20}{2}$$

2. Use relation

$$\left(\frac{\sigma_1 - \sigma_3}{2}\right) = \sqrt{\left[\sigma_{\theta} - \left(\frac{\sigma_1 + \sigma_3}{2}\right)\right]^2 + [\tau_{\theta}]^2}$$

with either pair of given stresses

$$\left(\frac{\sigma_1 - \sigma_3}{2}\right) = \sqrt{[20 - 30]^2 + [10]^2} = \sqrt{200} = 14.14 \text{ kN/m}^2$$

3. 
$$\sigma_1 = \left(\frac{\sigma_1 + \sigma_3}{2}\right) + \left(\frac{\sigma_1 - \sigma_3}{2}\right) = 44.14 \text{ kN/m}^2$$

$$\sigma_3 = \left( \frac{\sigma_1 + \sigma_3}{2} \right) - \left( \frac{\sigma_1 - \sigma_3}{2} \right) = 15.86 \text{ kN/m}^2$$

4. Use stress pair in which  $\sigma_\theta$  is largest; i.e. (40, -10)

$$\sin 2\theta = \frac{2\tau_\theta}{\sigma_1 - \sigma_3} = \frac{-20}{28.28} = -0.707$$

$$2\theta = -45^\circ$$

$$\theta = -22\frac{1}{2}^\circ$$

5. Angle from horizontal to major principal stress direction =  $30^\circ - \theta = 52\frac{1}{2}^\circ$ .

---

### **4.3 Stress Increment Soil**

Construction of a foundation causes changes in the stress. The net stress increase in the soil depends on the load per unit area to which the foundation is subjected, the depth below the foundation at which the stress estimation is desired, and other factors. It is necessary to estimate the net increase of vertical stress in soil that occurs due to construction so that settlement can be calculated. The estimation of vertical stress is based on the theory of elasticity. The loads may include:

Point load	Uniformly loaded rectangular area
Line load	
Uniformly distributed vertical strip load	Uniformly loaded circular area
Linearly increasing vertical loading on a strip	Embankment type of loading

Although natural soil deposits, in most cases, are not fully elastic, isotropic, or homogeneous materials, calculations for estimating increases in vertical stress yield fairly good results for practical work.

#### **4.3.1 Stresses Caused by a Point Load**

4.5.1 Boussinesq (1883) solved the problem of stresses produced at any point in a homogeneous, elastic, and isotropic medium as the result of a point load applied on the surface of an infinitely large half-space.



**Table .1** Variation of  $I_1$  for Various Values of  $r/z$  for point load

$r/z$	$I_1$	$r/z$	$I_1$	$r/z$	$I_1$
0	0.4775	0.36	0.3521	1.80	0.0129
0.02	0.4770	0.38	0.3408	2.00	0.0085
0.04	0.4765	0.40	0.3294	2.20	0.0058
0.06	0.4723	0.45	0.3011	2.40	0.0040
0.08	0.4699	0.50	0.2733	2.60	0.0029
0.10	0.4657	0.55	0.2466	2.80	0.0021
0.12	0.4607	0.60	0.2214	3.00	0.0015
0.14	0.4548	0.65	0.1978	3.20	0.0011
0.16	0.4482	0.70	0.1762	3.40	0.00085
0.18	0.4409	0.75	0.1565	3.60	0.00066
0.20	0.4329	0.80	0.1386	3.80	0.00051
0.22	0.4242	0.85	0.1226	4.00	0.00040
0.24	0.4151	0.90	0.1083	4.20	0.00032
0.26	0.4050	0.95	0.0956	4.40	0.00026
0.28	0.3954	1.00	0.0844	4.60	0.00021
0.30	0.3849	1.20	0.0513	4.80	0.00017
0.32	0.3742	1.40	0.0317	5.00	0.00014
0.34	0.3632	1.60	0.0200		

**Example (4.13)**

Consider a point load  $P = 5 \text{ kN}$ , calculate the vertical stress increase  $\Delta\sigma_z$  at  $z = 0, 2 \text{ m}, 4 \text{ m}, 6 \text{ m}, 10 \text{ m},$  and  $20 \text{ m}$ . Given  $x = 3 \text{ m}$  and  $y = 4 \text{ m}$ .

**Solution**

$$r = \sqrt{x^2 + y^2} = \sqrt{3^2 + 4^2} = 5 \text{ m}$$

the following table can be prepare

$r$ (m)	$z$ (m)	$\frac{r}{z}$	$I_1$	$\Delta\sigma_z = \left(\frac{P}{z^2}\right)I_1$ (kN/m <sup>2</sup> )
5	0	$\infty$	0	0
	2	2.5	0.0034	0.0043
	4	1.25	0.0424	0.0133
	6	0.83	0.1295	0.0180
	10	0.5	0.2733	0.0137
	20	0.25	0.4103	0.0051

**4.3.2 Vertical Stress Caused by a Vertical Line Load**

The stresses increment due to line load can be calculated using the following equation:

$$\frac{\Delta\sigma_z}{(q/z)} = \frac{2}{\pi[(x/z)^2 + 1]^2}$$

**Table .2** Variation of  $\Delta\sigma_z/(q/z)$  with  $x/z$  for line lo

$x/z$	$\Delta\sigma_z/(q/z)$	$x/z$	$\Delta\sigma_z/(q/z)$
0	0.637	1.3	0.088
0.1	0.624	1.4	0.073
0.2	0.589	1.5	0.060
0.3	0.536	1.6	0.050
0.4	0.473	1.7	0.042
0.5	0.407	1.8	0.035
0.6	0.344	1.9	0.030
0.7	0.287	2.0	0.025
0.8	0.237	2.2	0.019
0.9	0.194	2.4	0.014
1.0	0.159	2.6	0.011
1.1	0.130	2.8	0.008
1.2	0.107	3.0	0.006

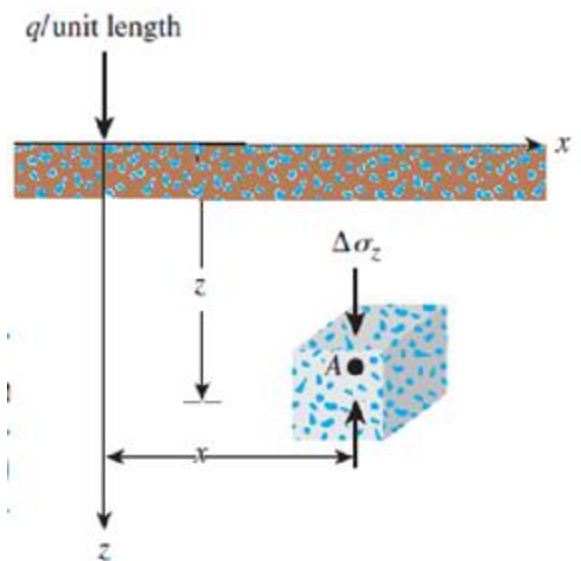



### Example (4.14)

Figure shows two line loads on the ground surface. Determine the

$$\Delta\sigma_z = \Delta\sigma_{z(1)} + \Delta\sigma_{z(2)}$$

$$\sigma_{z(1)} = \frac{2q_1z^3}{\pi(x_1^2 + z^2)^2} = \frac{(2)(7.5)(4)^3}{\pi(5^2 + 4^2)^2} = 0.182 \text{ kN/m}^2$$

$$\sigma_{z(2)} = \frac{2q_2z^3}{\pi(x_2^2 + z^2)^2} = \frac{(2)(15)(4)^3}{\pi(10^2 + 4^2)^2} = 0.045 \text{ kN/m}^2$$

$$\Delta\sigma_z = 0.182 + 0.045 = 0.227 \text{ kN/m}^2$$

increase of stress at point A.

### Solution

The total stress at A is

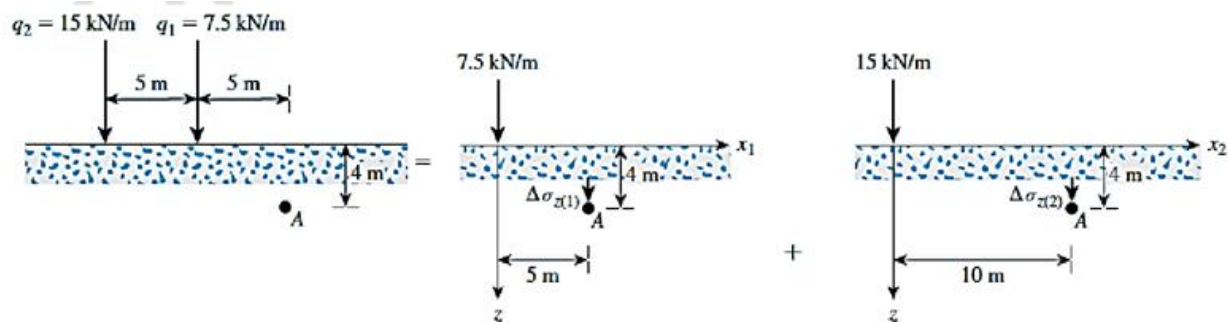

### 4.3.3 Vertical and horizontal Stresses Caused by a Vertical Uniform Distributed Load on Circular Area

F: factor, can be find from the following figure

R: is the radius of the circular area

X: is the distance from the center of the circle to the point

Z: is the depth of the point.

### Example (4.15)

For the soil with  $g = 16.5 \text{ kN/m}^2$  and  $k_o = 0.5$  loaded by  $\Delta q_s = 240 \text{ kN/m}^2$  over circular area of 6m in diameter. Find vertical and horizontal stresses at depth of 3m under the center of the loaded area.

### Solution

Initial stresses:  $s_v = 16.5 * 3 = 49.3 \text{ kN/m}^2$ ,  $s_h = 49.3 * 0.5 = 24.75 \text{ kN/m}^2$

Stress increment:

$X = 0, R = 3, z = 3$   $X/R = 0$ ,  $z/R = 1$

Let  $\Delta s_v = \Delta s_1$  and  $\Delta s_h = \Delta s_3$

$F = 0.64$  for vertical and  $0.64 - 0.54 = 0.1$

$\Delta s_v = 0.64 * 240 = 153.6 \text{ kN/m}^2$ ,  $\Delta s_h = 0.1 * 240 = 24 \text{ kN/m}^2$

$s_{vf} = 153.6 + 49.3 = 202.9 \text{ kN/m}^2$ ,  $s_{hf} = 24 + 24.75 = 48.75 \text{ kN/m}^2$

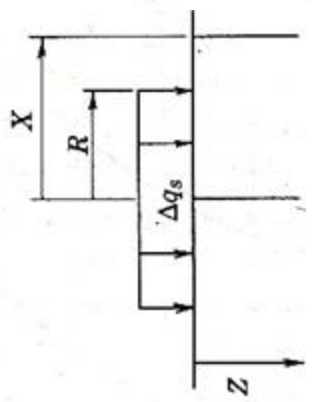
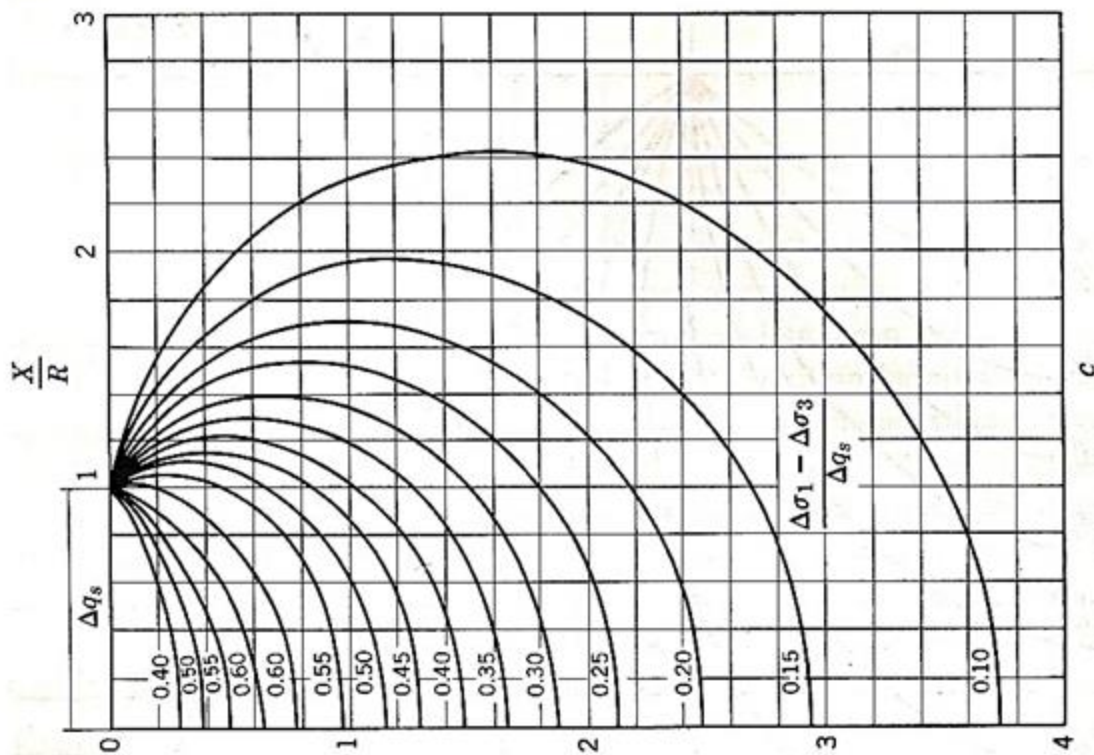

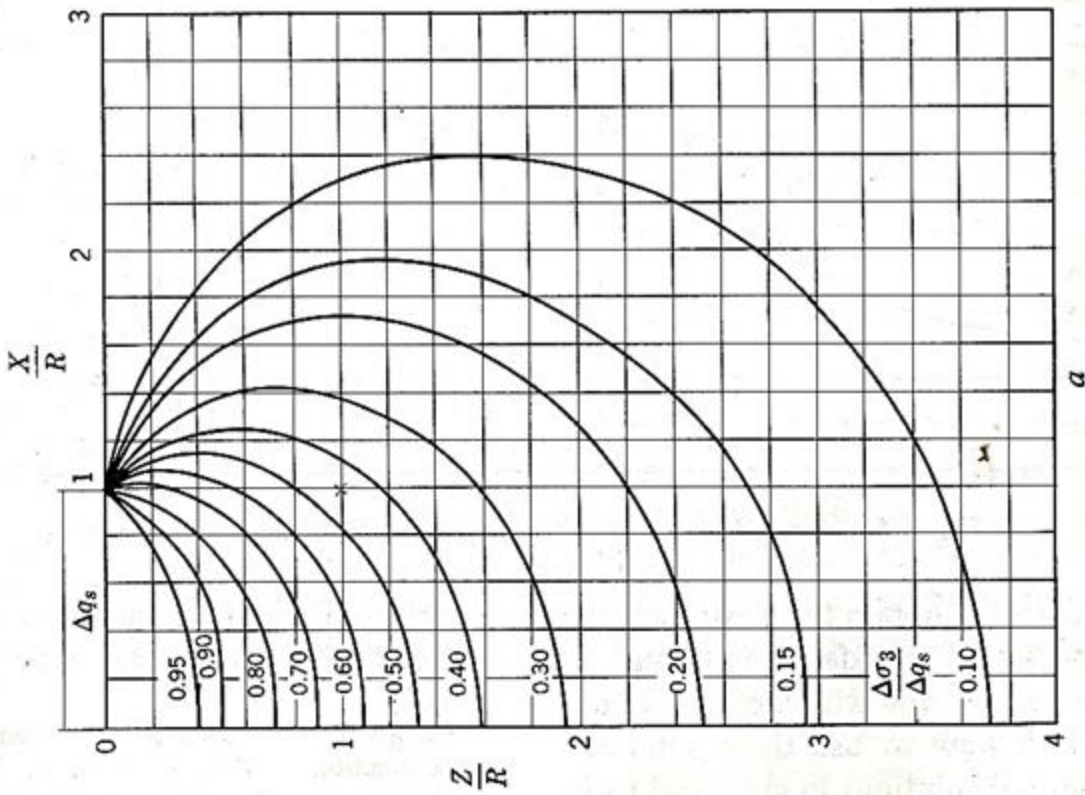

Stresses under uniform load on circular area

4.3.4 Vertical and Horizontal Stresses Caused by a Vertical Distributed Load on Strip

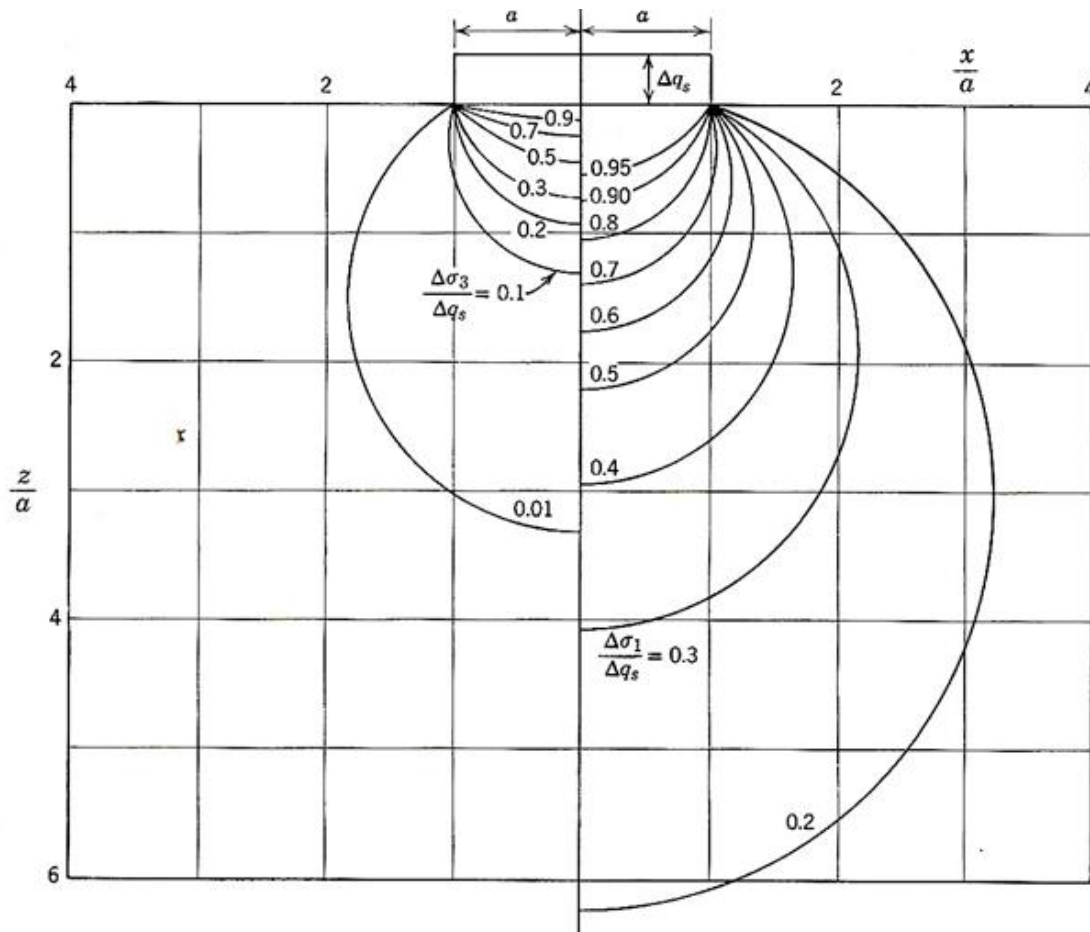

Principle stresses under Strip area

#### 4.3.5 Vertical and Horizontal Stressed Caused by a triangular Load on Strip

Use the following figure

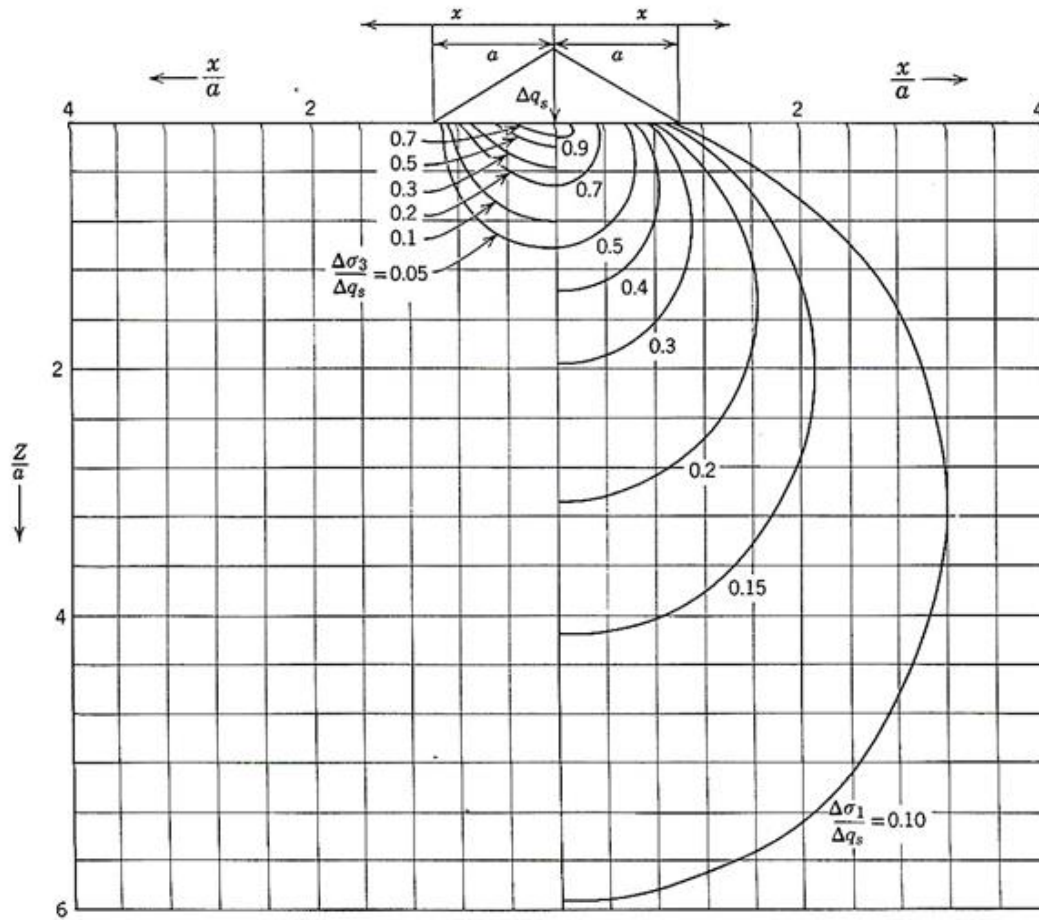

Principal stresses under triangular strip load.

#### 4.3.6 Vertical Stress Caused by a Uniform distributed Load on Rectangular Surface

**Example (4.16)**

Find the vertical stress increment at depth of 10m below point A due to loading area of  $\Delta q_s = 240 \text{ kN/m}^2$ .

**Solution**

Divided the shape into:

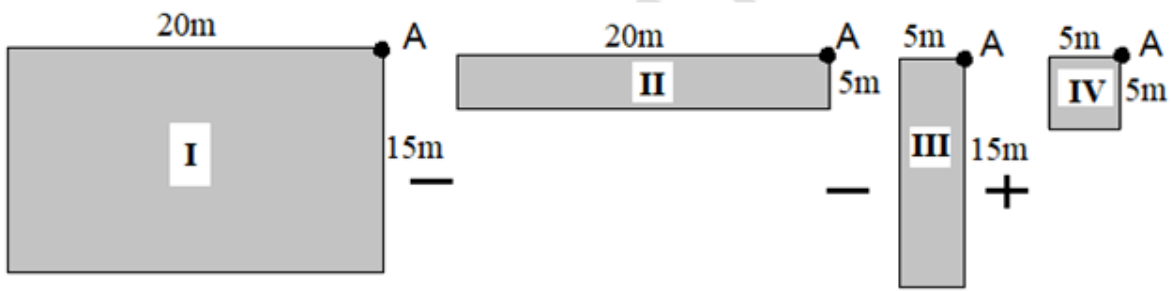
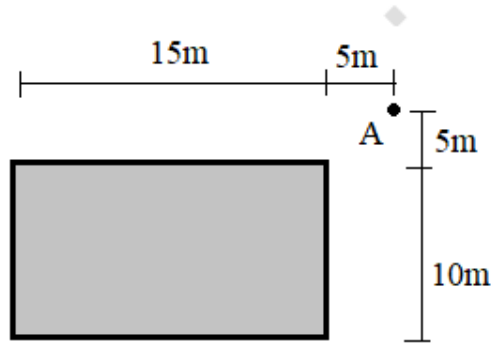

Loading	m	n	Coeff	$\Delta q_s$	Factor	Stress increment, $\Delta\sigma \text{ kN/m}^2$
I	$15/10=1.5$	$20/10=2.0$	0.223	240	+1	+ 22.3
II	$5/10=0.5$	$20/10=2.0$	0.135	240	-1	- 13.5
III	$15/10=1.5$	$5/10=0.5$	0.131	240	-1	- 13.1
IV	$5/10=0.5$	$5/10=0.5$	0.085	240	+1	+ 8.5
Total stress increment						4.2

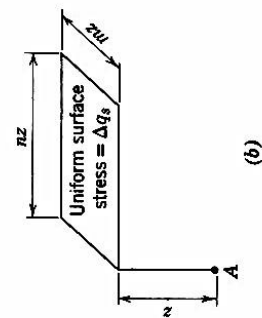
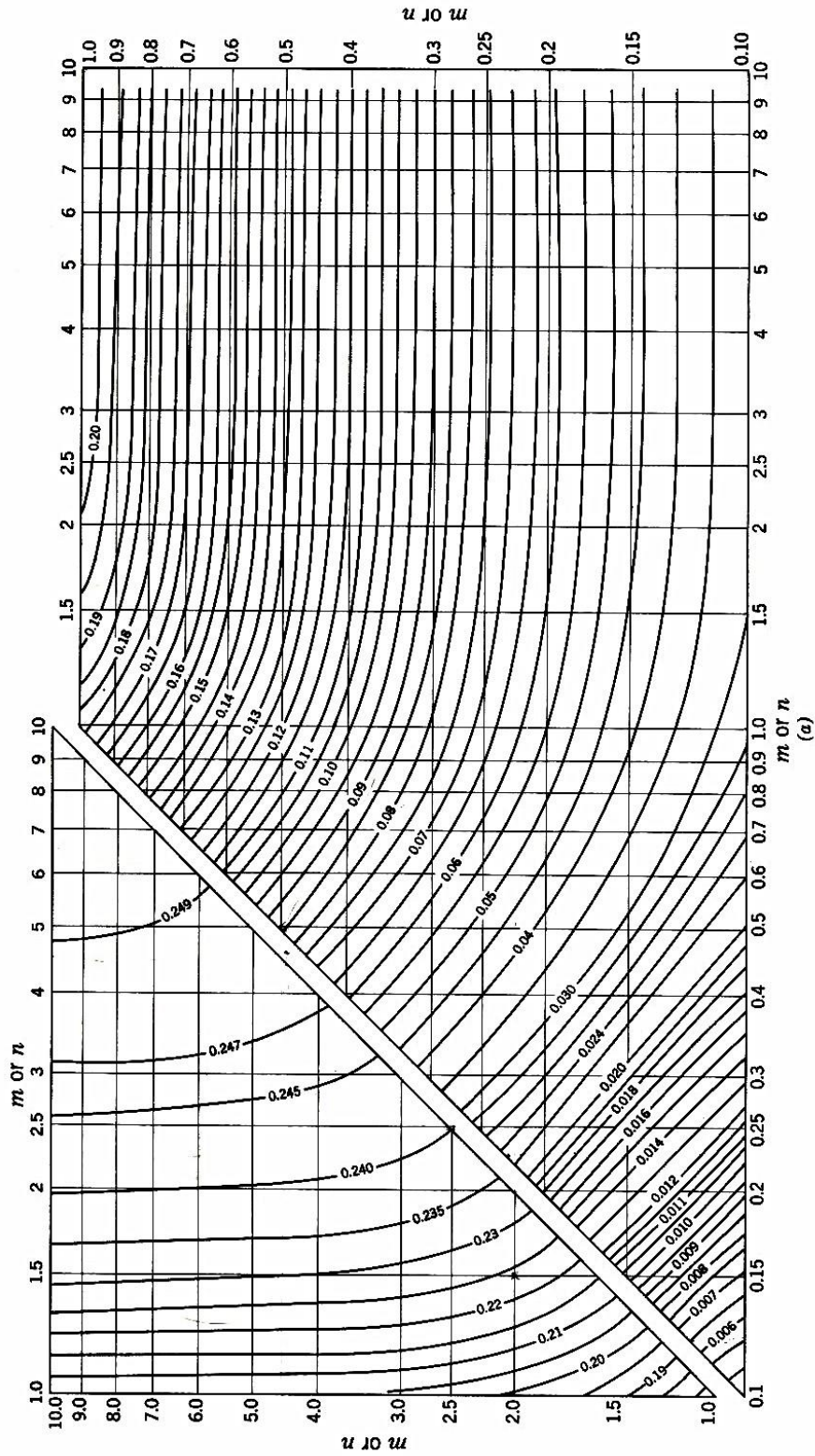

(a) Chart for use in determining vertical stresses below corners of loaded rectangular surface areas on elastic, isotropic material. Chart gives  $f(m, n)$ . (b) At point  $A$ ,  $\Delta\sigma_v = \Delta q_s \times f(m, n)$ . (From Newmark, 1942)



### Example (4.17)

For the loaded area a uniform pressure of  $100 \text{ kN/m}^2$ . Compute the vertical stress at depth of 12m below point A.

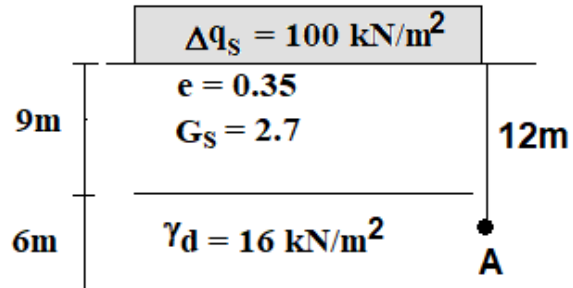
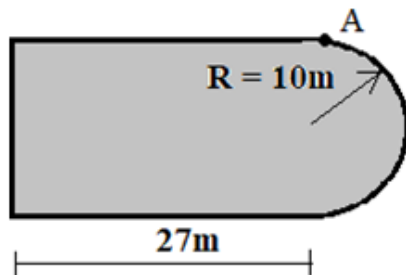

### Solution

$$\gamma_d = \frac{G_s * \gamma_w}{1 + e} = \frac{2.7 * 9.81}{1 + 0.35} = 19.62 \text{ kN/m}^2$$

$$\sigma_v @ 12\text{m} = 9 * 19.62 + 16 * 3 = 224.58 \text{ kN/m}^2$$

Divided the area to :

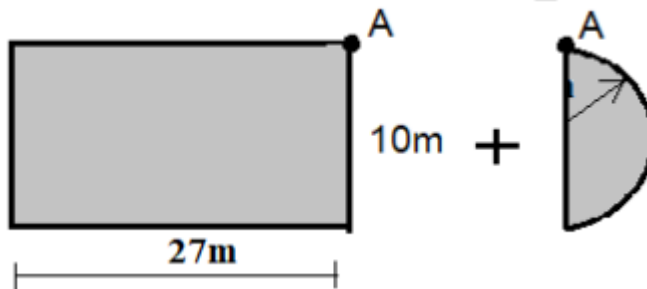

For circular area

$$X/R = 1, z/R = 1.2, F = 0.3$$

$$\text{for vertical stress} = \Delta\sigma_v = 0.3 * 0.5 * 100 = 15 \text{ kN/m}^2$$

For rectangular area

$$n = 1.66, m = 2.25, \text{coeff.} = 0.23 \therefore \Delta\sigma_v = 0.23 * 100 = 23 \text{ kN/m}^2,$$

$$\sigma_{vf} = 15 + 23 + 224.58 = 262.58 \text{ kN/m}^2$$

Loading	X/R	Z/R	<u>Coeff.</u>	$\Delta q_s$	Factor	Stress increment, $\Delta\sigma$ kN/m <sup>2</sup>
I	1/10=0.1	5/10=0.5	0.9	100	0.5	45

Loading	m	n	<u>Coeff.</u>	$\Delta q_s$	Factor	Stress increment, $\Delta\sigma$ kN/m <sup>2</sup>
II	27/5=5.4	6/5=1.2	0.215	100	0.5	10.75
III	27/5=5.4	20/5=4	0.248	100	1	24.8
Total stress increment						80.55

**Example (4.18)**

For the loaded area with uniform pressure on the ground surface with  $\Delta q_s = 100 \text{ kN/m}^2$  as shown in figures. Compute the increment in vertical stresses at 5m below point A.

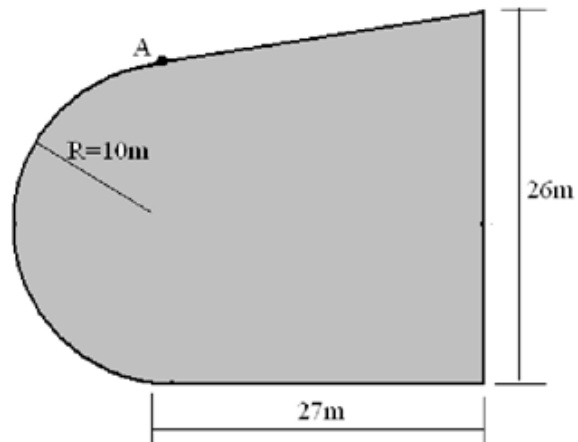

**Solution**

Divided the area into

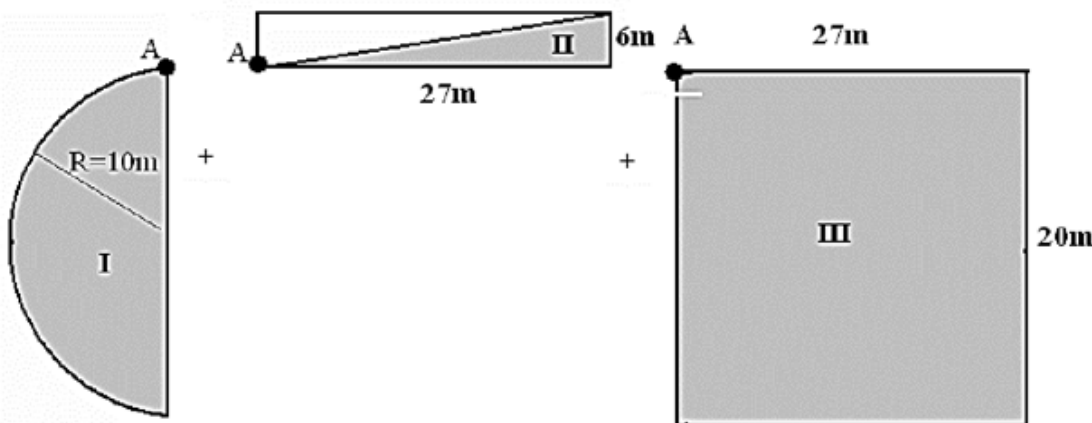

**4.4 Vertical Stress Due to Embankment Loading**

The figure shows the cross section of an embankment of height H. For this two dimensional loading condition the vertical stress increase may be expressed as

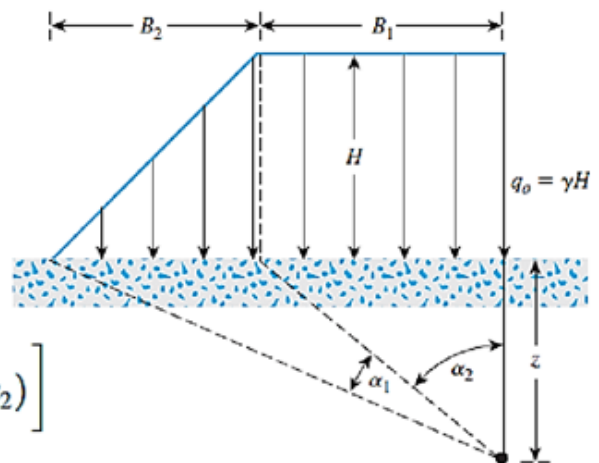

$$\Delta\sigma_z = \frac{q_0}{\pi} \left[ \left( \frac{B_1 + B_2}{B_2} \right) (\alpha_1 + \alpha_2) - \frac{B_1}{B_2} (\alpha_2) \right]$$

$$\Delta\sigma_z = \frac{q_o}{\pi} \left[ \left( \frac{B_1 + B_2}{B_2} \right) (\alpha_1 + \alpha_2) - \frac{B_1}{B_2} (\alpha_2) \right]$$

Where,  $q_o = \gamma H$

$\gamma$  = unit weight of the embankment soil

H = height of the embankment

$$\alpha_1 \text{ (radians)} = \tan^{-1}\left(\frac{B_1 + B_2}{z}\right) - \tan^{-1}\left(\frac{B_1}{z}\right)$$

$$\alpha_2 = \tan^{-1}\left(\frac{B_1}{z}\right)$$

$$\Delta\sigma_z = q_0 I_2$$

Where,  $I_2 =$  a function of  $B_1/z$  and  $B_2/z$ .

The variation of  $I_2$  with  $B_1/z$  and  $B_2/z$  is shown in Figure

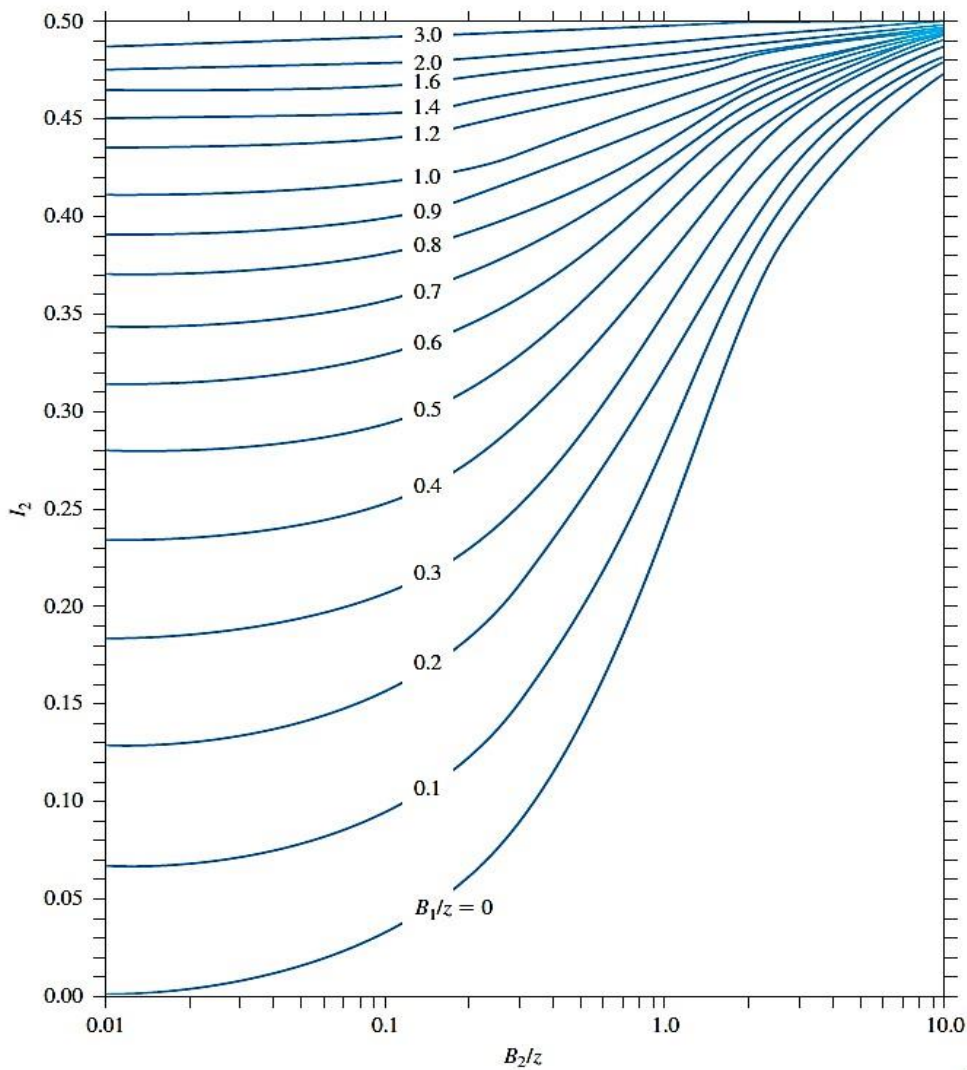

Osterberg's chart for determination of vertical stress due to embankment loading

**Example (4.19)**

An embankment is shown in Figure. Determine the stress increase under the embankment at points A1 and A2.

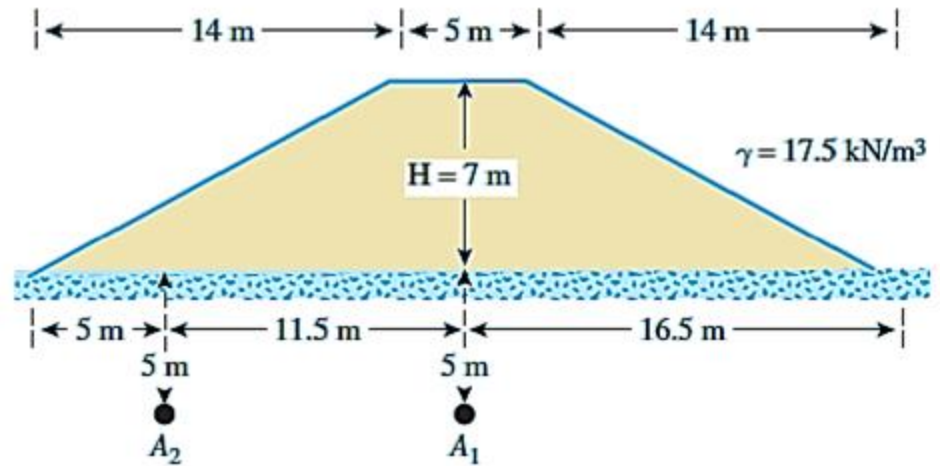

**Solution**

Stress Increase at A1

$$gH = 17 * 7 = 122.5 \text{ kN/m}^2$$

The left side of the figure below indicates that  $B_1 = 2.5 \text{ m}$  and  $B_2 = 14 \text{ m}$ .  
So,

$$\frac{B_1}{z} = \frac{2.5}{5} = 0.5; \frac{B_2}{z} = \frac{14}{5} = 2.8$$

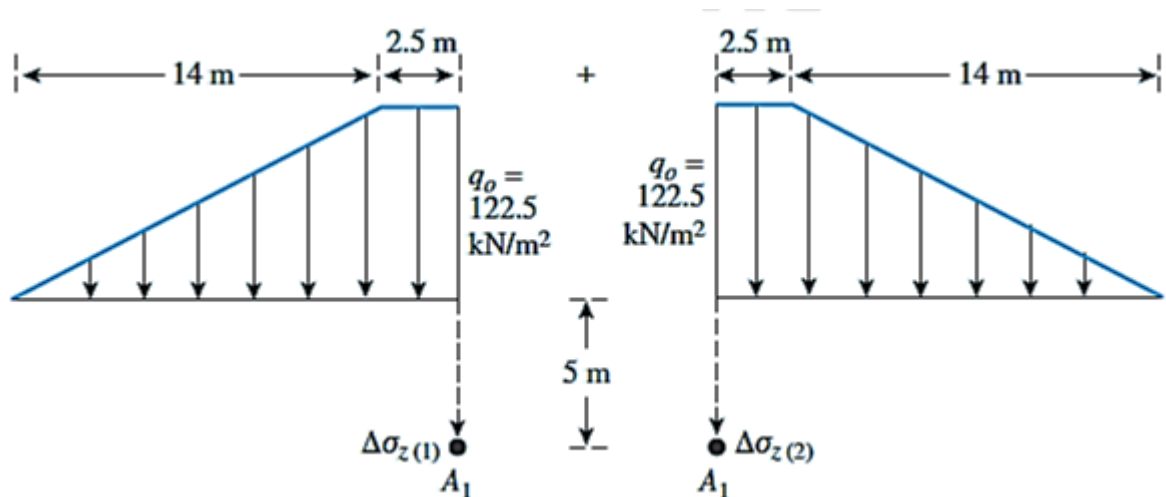

According to Osterberg's chart, in this case,  $I_2 = 0.445$

Because the two sides in this figure are symmetrical, the value

of  $I_2$  for the right side will also be 0.445. So

$$\begin{aligned}\Delta\sigma_z &= \Delta\sigma_{z(1)} + \Delta\sigma_{z(2)} = q_o[I_{2(\text{Left})} + I_{2(\text{Right})}] \\ &= 122.5[0.445 + 0.445] = 109.03 \text{ kN/m}^2\end{aligned}$$

Stress Increase at  $A_2$

Refer to Figure below. For the left side,  $B_2 = 5 \text{ m}$  and  $B_1 = 0$ .

$$\Delta\sigma_{z(1)} = 43.75(0.24) = 10.5 \text{ kN/m}^2$$

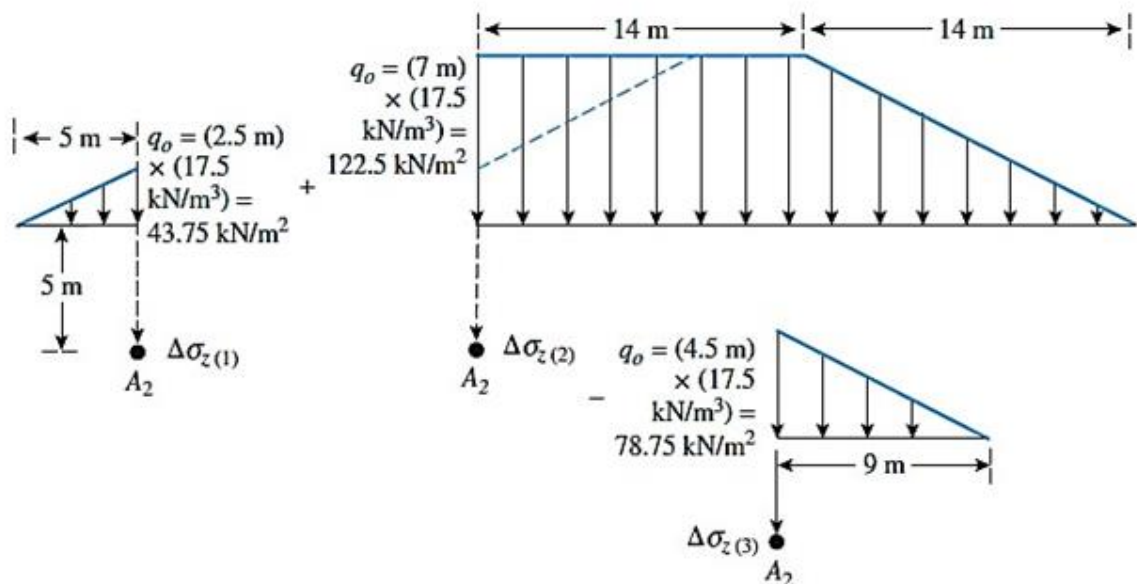

According to Osterberg's chart, for these values of  $B_2/z$  and  $B_1/z$ ,  $I_2 = 0.24$ . So,

For the middle section,

$$\frac{B_2}{z} = \frac{14}{5} = 2.8; \frac{B_1}{z} = \frac{14}{5} = 2.8$$

Thus,  $I_2 = 0.495$ . So,  $\Delta\sigma_{z(2)} = 0.495(122.5) = 60.64 \text{ kN/m}^2$

For the right side,

$$\frac{B_2}{z} = \frac{9}{5} = 1.8; \frac{B_1}{z} = \frac{0}{5} = 0$$

and  $I_2 = 0.335$  So,  $\Delta\sigma_{z(3)} = (78.75)(0.335) = 26.38 \text{ kN/m}^2$

Total stress increase at point  $A_2$  is

$$\Delta\sigma_z = \Delta\sigma_{z(1)} + \Delta\sigma_{z(2)} - \Delta\sigma_{z(3)} = 10.5 + 60.64 - 26.38 = 44.76 \text{ kN/m}^2$$

#### 4.4 Method 2:1

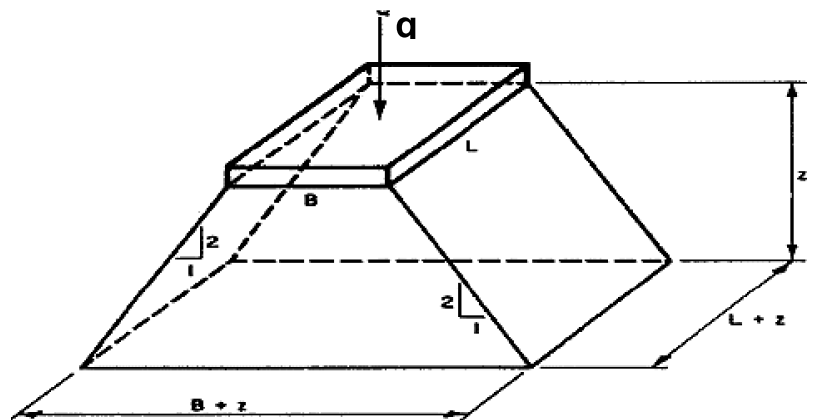
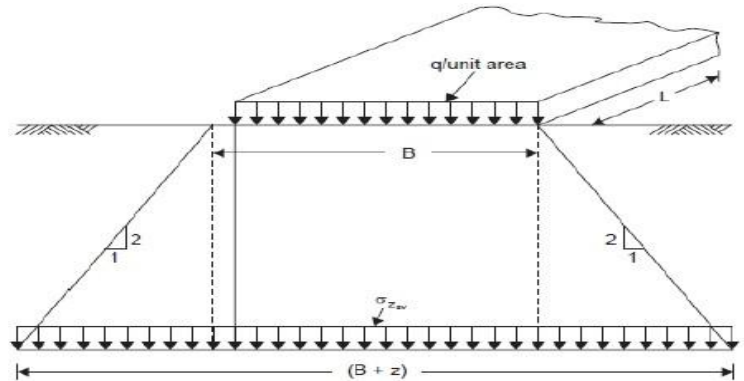

$$\Delta\sigma_z = \frac{Q}{(B+Z)(L+Z)}$$

Rectangular area

$$\Delta\sigma_z = \frac{Q}{(B+Z)^2}$$

Square area

$$\Delta\sigma_z = \frac{Q}{\frac{\pi}{4}(D+Z)^2}$$

Circular area



## Homework Chapter 4

4.1 For the soil profile shown calculate the total, effective vertical stresses and pore water pressure.

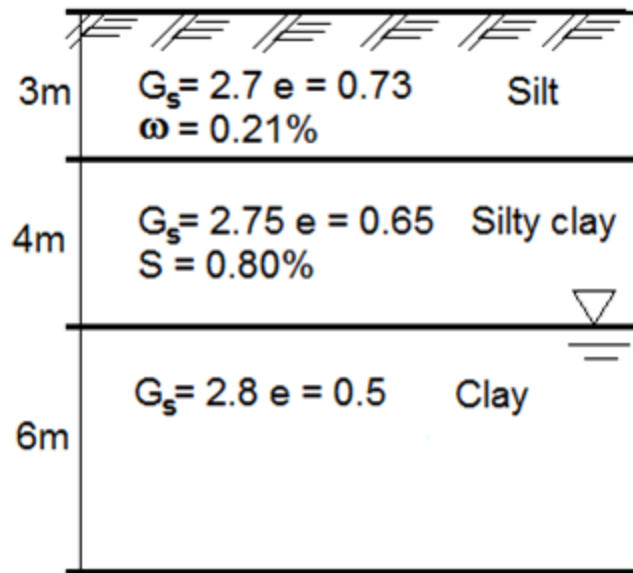

4.2 Draw the stresses  $\sigma$ ,  $u$ , and  $\sigma'$  with depth for the profile shown.

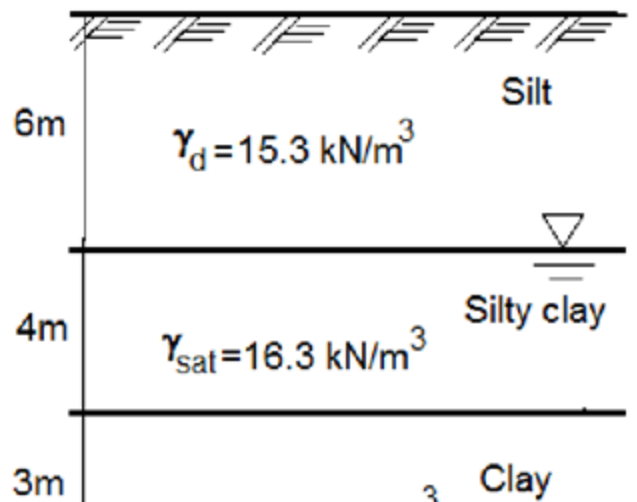

4.3 A soil profile consisting of three layers is shown in the figure. Calculate the values of  $\sigma$ ,  $u$ , and  $\sigma'$  at points A, B, C, and D and plot the

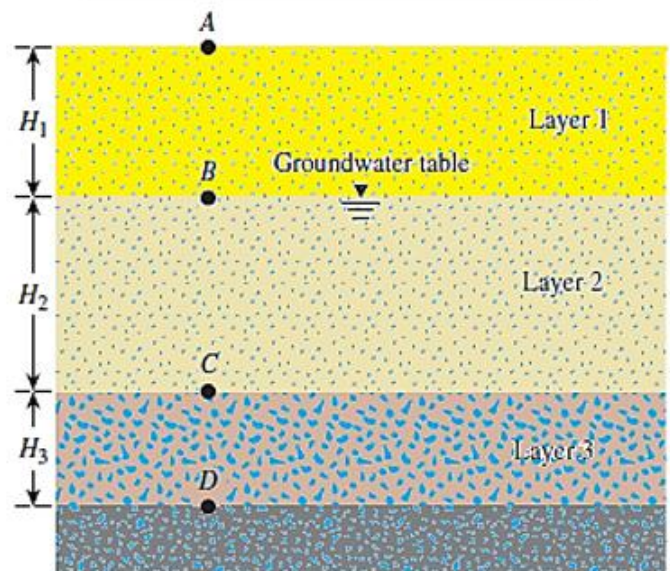

Dry sand
  Sand
  Clay
  Rock

variations of  $\sigma$ ,  $u$ , and  $\sigma'$  with depth. Characteristics of layers 1, 2, and three are given below:

Layer no.	Thickness	Soil parameters
1	$H_1 = 2.1 \text{ m}$	$\gamma_d = 17.23 \text{ kN/m}^3$
2	$H_2 = 3.66 \text{ m}$	$\gamma_{\text{sat}} = 18.96 \text{ kN/m}^3$
3	$H_3 = 1.83 \text{ m}$	$\gamma_{\text{sat}} = 18.5 \text{ kN/m}^3$

4.4 Redo problem 4.3 for the same profile but with following soil characteristics.

Layer no.	Thickness	Soil parameters
1	$H_1 = 5 \text{ m}$	$e = 0.7; G_s = 2.69$
2	$H_2 = 8 \text{ m}$	$e = 0.55; G_s = 2.7$
3	$H_3 = 3 \text{ m}$	$w = 38\%; e = 1.2$

4.5 Redo problem 4.3 for the same profile but with following soil characteristics.

Layer no.	Thickness	Soil parameters
1	$H_1 = 3 \text{ m}$	$\gamma_d = 16 \text{ kN/m}^3$
2	$H_2 = 6 \text{ m}$	$\gamma_{\text{sat}} = 18 \text{ kN/m}^3$
3	$H_3 = 2.5 \text{ m}$	$\gamma_{\text{sat}} = 17 \text{ kN/m}^3$

- 4.6 Consider the soil profile in Problem 4.2. What is the change in effective stress at point C if:
- The water table drops by 2 m
  - The water table rises to the surface up to point A
  - Water level rises 3 m above point A due to flooding

4.7 Consider the soil profile shown in Figure:

- Calculate the variations of  $\sigma$ ,  $u$ , and  $\sigma'$  at points A, B, and C.
- How high should the
- groundwater table rise so that the effective stress at C is  $111 \text{ kN/m}^2$

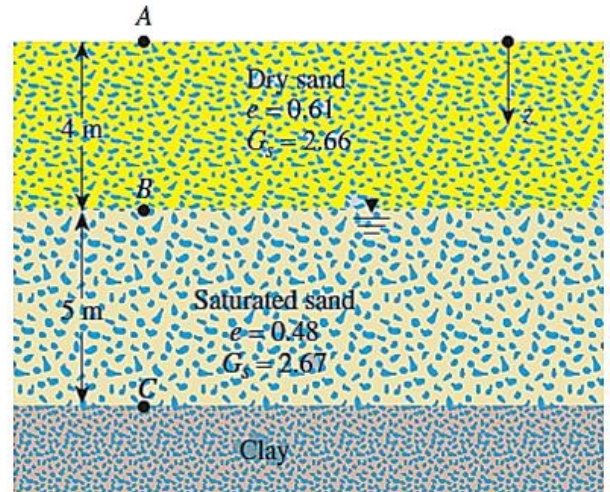

4.8 For the stressed soil element shown in Figure, determine

- Major principal stress
- Minor principal stress
- Normal and shear stresses on the plane DE

(Ans.) a) Major principal stress =  $170.7 \text{ kN/m}^2$ , b) Minor principal stress =  $29.3 \text{ kN/m}^2$ , c) Normal stress =  $164 \text{ kN/m}^2$ , Shear stress =  $-29.9 \text{ kN/m}^2$

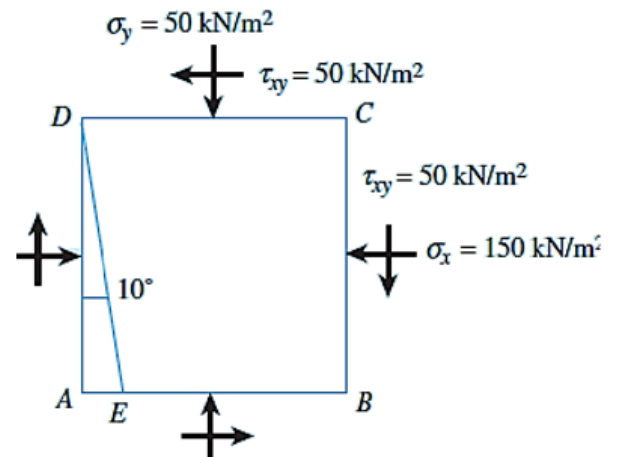

4.9 A soil elements are shown in Figures.

Determine the following (by drawing and equations):

- Maximum and minimum principal stresses
- Normal and shear stresses on plane AB

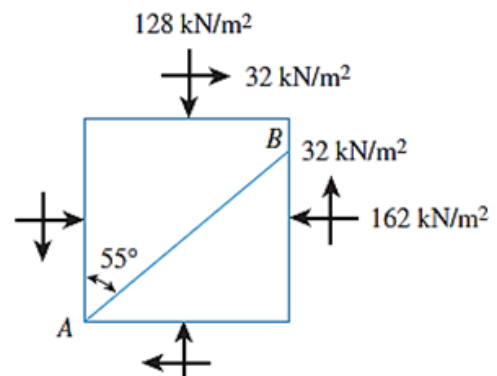
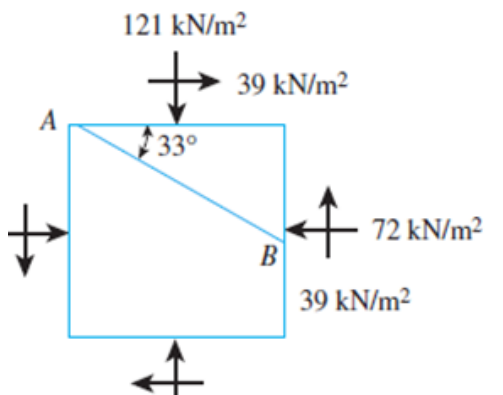

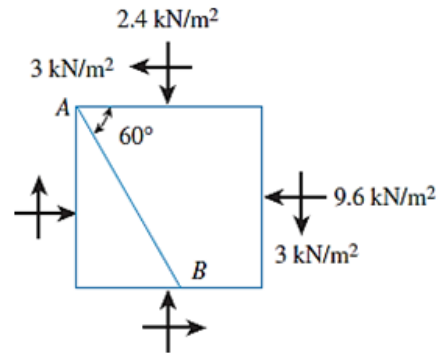
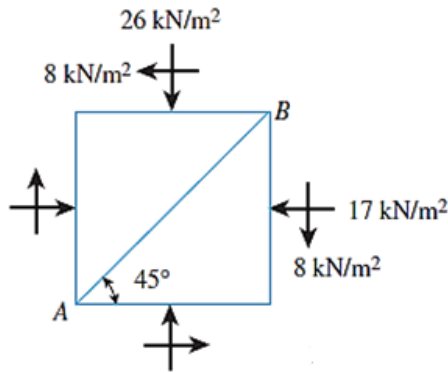

- (Ans.)
- a. 1.  $\sigma_1 = 181.23 \text{ kN/m}^2$ ;  $\sigma_3 = 108.76 \text{ kN/m}^2$   
 2.  $\sigma_n = 169.25 \text{ kN/m}^2$ ;  $\tau_n = -26.92 \text{ kN/m}^2$
  - c. 1.  $\sigma_1 = 30.68 \text{ kN/m}^2$ ;  $\sigma_3 = 12.32 \text{ kN/m}^2$   
 2.  $\sigma_n = 13.53 \text{ kN/m}^2$ ;  $\tau_n = 4.55 \text{ kN/m}^2$

4.10 Point loads of magnitude 100, 200, and 400 kN act at B, C, and D, respectively. Determine the increase in vertical stress at a depth of 6 m below the point A. Use Boussinesq's equation.

Ans. 1,127 kN/m<sup>2</sup>

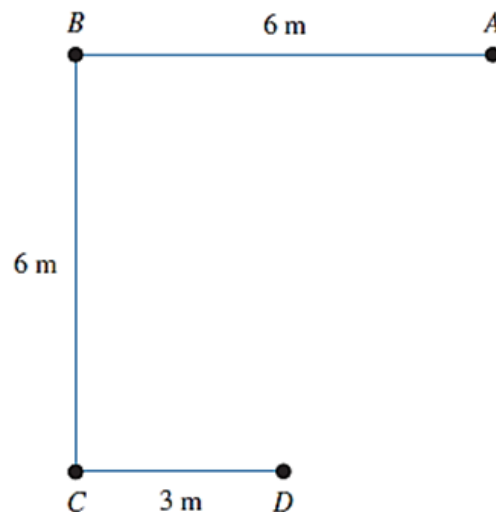

4.11 Determine the vertical stress increase,  $\Delta\sigma_z$ , at point A with the following values:  
 $q_1 = 90 \text{ kN/m}$ ;  $q_2 = 325 \text{ kN/m}$ ;  
 $x_1 = 4 \text{ m}$ ;  $x_2 = 2.5 \text{ m}$ ;  $z = 3 \text{ m}$ .

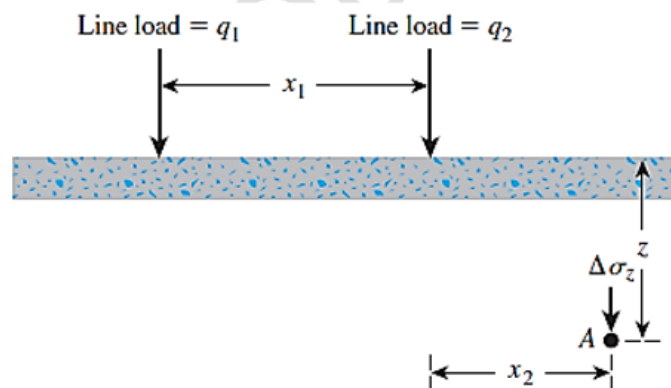

4.12 For the loaded area with uniform pressure on the ground surface with

$\Delta q_s = 100 \text{ kN/m}^2$  as shown in figures. Compute the increment in vertical stresses at 5m below point A.

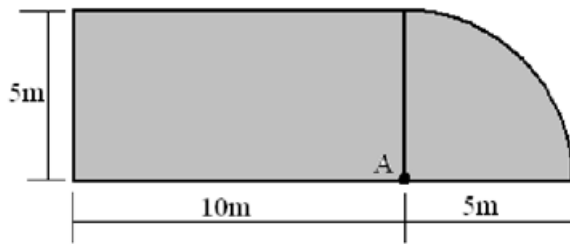

**A**

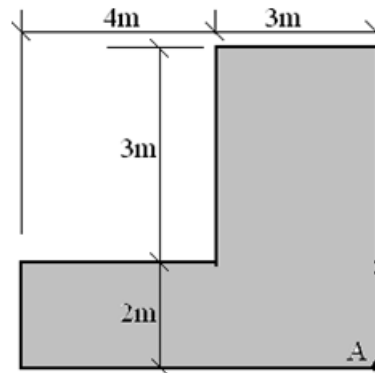

**B**

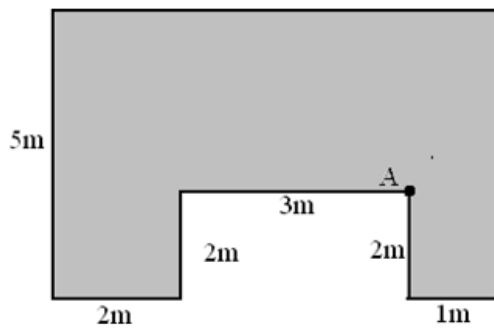

**C**

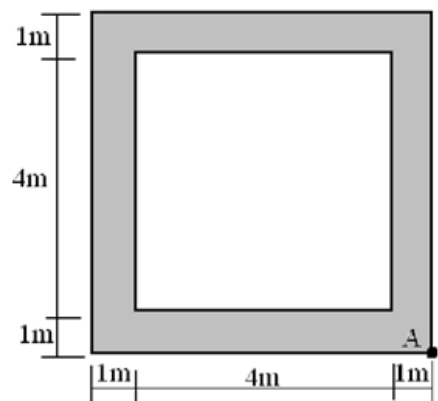

**D**

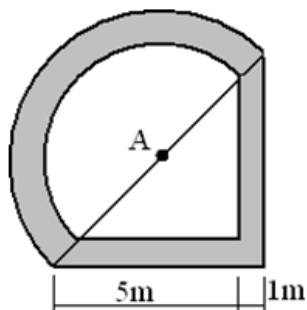

**E**

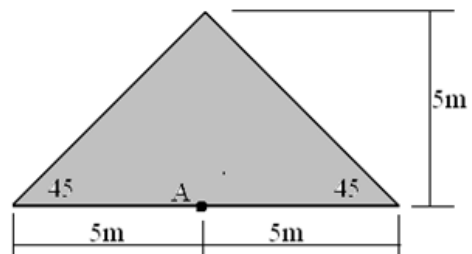

**F**

Ans. A = 36 kN/m<sup>2</sup>, B = 16.5 kN/m<sup>2</sup>, C = 80.55 kN/m<sup>2</sup> D = 1.8 kN/m<sup>2</sup> E = 26 kN/m<sup>2</sup> F = 10.6 kN/m<sup>2</sup>

4.13 An earth embankment is shown in Figure. Determine the stress increase at point A due to the embankment load.

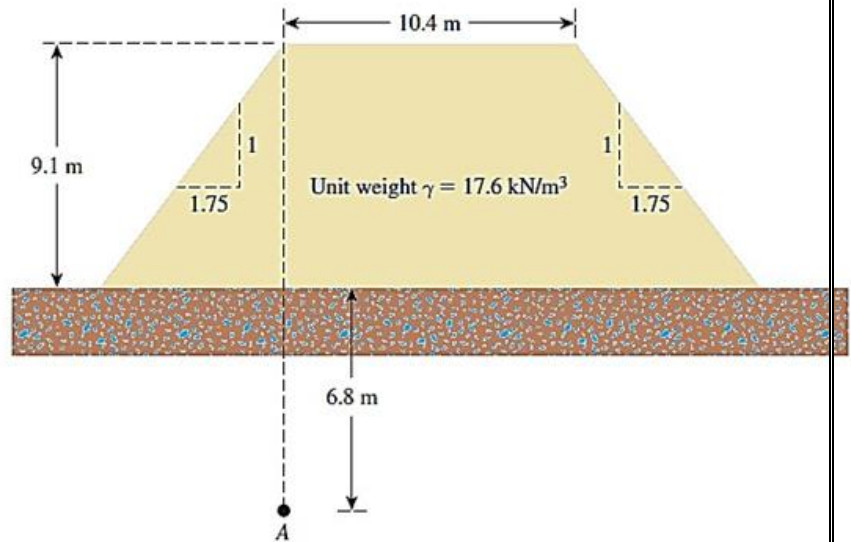

4.1

4.14 For the embankment loading shown in Figure, determine the vertical stress increases at points A, B, and C.

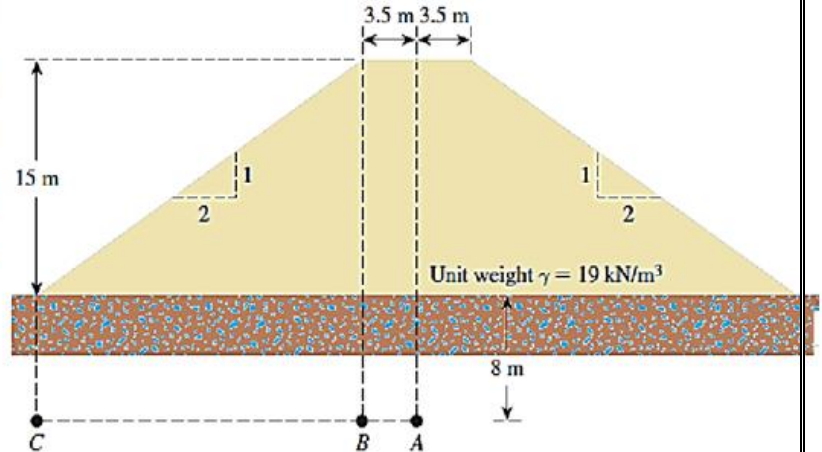

4.15 A circular area on the ground surface is subjected to a uniformly distributed load,  $q = 105 \text{ kN/m}^2$ . If the circular area has a radius,  $R = 3.6 \text{ m}$ , determine the vertical stress increase, at points 0, 1.2, 2.4, 4.8 and 9.6 m below the ground surface along the centerline of the circular area.

4.16 A circular area of radius,  $R = 5 \text{ m}$  subjected to a uniformly distributed load,  $q = 380 \text{ kN/m}^2$ . Determine the vertical stress increases 3 m below the loaded area at radial distances,  $r = 0, 1, 3, 5,$  and  $7 \text{ m}$ .

4.17 Refer to Figure. A rectangular area is uniformly loaded by  $q = 225 \text{ kN/m}^2$ . Using Newmark's chart, determine the increase in vertical stress, at points A, B and C at depth of 3m.

